

SERVICE INSTRUCTIONS

**COMPATIBLE SUPER 8
AND STANDARD 8
AUTOLOAD[®] PROJECTOR**

DESIGN 456A AND 456Z

finer products through imagination

Bell & Howell
PHOTO SALES COMPANY

**GENERAL SERVICE DEPT.
7100 N. McCORMICK ROAD
CHICAGO, ILLINOIS 60645**

PART NO. 70491

PRINTED IN U.S.A.

NOVEMBER 1966

SERVICE INSTRUCTIONS



FEATURE DESCRIPTION LIST

Color:	
Base	Silver
Covers	Walnut Brown
Mainplate	Silver
Lamphouse	Walnut Brown
Type of film	Super 8-mm and Standard 8-mm
Projector operation	Forward-still-reverse
Still projection filter	Glass and metal screen
Type of framer	Screw knob
Projection lamp	DJL 120 volt, 155 watt, with metal reflector
Loopformer system	Hold-down
Projection lens	1" f/1.5 (B & H No. 020749) 19.3/32.5mmf/1.5 zoom (B & H No. 020748)
Operating voltage	120 volts, 60 cycles, AC
Motor	120 volts, 60 cycles
Tilt device	Gravity foot - knob locked
Weight	15 lbs. 2 oz.
Special features	Film trimmer mounted on base

Introduction

GENERAL.

This manual has been prepared to aid in the servicing and repair of the Bell & Howell Compatible 8-mm and Super 8-mm Autoload Projector, Design 456. An Illustrated Parts Catalog is included at the rear of the manual to identify replacement parts and to aid the serviceman in the disassembly and reassembly of the projector.

All parts in the Parts Catalog exploded view illustrations are indexed in a suggested order of disassembly, with attaching parts immediately preceding those parts which they attach. Where disassembly and reassembly of parts is purely mechanical and no critical adjustments are involved, no attempt has been made to elaborate on the removal or installation of such items. When making specific projector repairs, the serviceman must use his own judgment in eliminating unnecessary steps of procedure. Illustrations referred to by letter (Figure A, Figure B) will be found in the Service Instructions portion of the manual, while those identified by number will be found in the Parts Catalog section.

DESCRIPTION.

The Design 456 Projector uses either standard 8-mm or super 8-mm film and is equipped with self-latching loopformers for fully automatic film threading. Special design features are listed in the Feature Description List. Note that the projector uses the Type DJL (120 volts, 150 watts) projection lamp.

AUTOLOAD THREADING (Figure A).

a. Before attempting to thread the film, place the Format Selector Lever into either the Super 8 or Regular 8 position, depending on the film which is to be shown. The Format Selector Lever can only be operated in the "OFF" position of the control switch.

b. To thread the film, the end is trimmed with the film cutter mounted on the projector base. Place the control switch in the "MOTOR" position and the direction lever in the "FORWARD" position. Depress the film threading lever (1) down and feed the cut end of the film leader between the two metal guide rollers (2) until the projector pulls film from the front reel. Allow about six inches of the film leader to enter the projector, or until the clicking of the shuttle can be heard. Release the film threading lever gently to its original position.

NOTE

Failure to release the film threading lever as soon as the clicking is heard may cause a threading malfunction.

The film will now thread itself through the projector automatically, and attach itself to the take-up reel. Once the leader begins to take up on the hub of the reel, the "MOTOR-LAMP" switch is pressed to the "LAMP" position to initiate film projection.

SPECIAL MAINTENANCE PRECAUTIONS.

The removal and installation of projector parts is comparatively simple and, for the most part, requires tools normally available in most repair shops (retaining ring pliers, Bristol setscrew wrenches, assorted screwdrivers and socket hex wrenches, etc.). Where required, special tools and gages are clearly noted in the instructions and illustrated in Figure B.

When repairing equipment, be sure that the work table surface is clean. As parts are removed, group them in an orderly fashion to avoid confusion during reassembly. Clean dirt and old lubricant from parts (except electrical components) by washing them in a pan of solvent. Hardened film emulsion can be removed from film path parts by using alcohol and a wooden implement (tooth pick or orange stick). Do not use a knife or other metal tool to scrape film emulsion from film path component.

After the projector has been repaired, reassembled and adjusted, perform the inspections and test procedures outlined in the Final Test section to insure satisfactory projector operation.

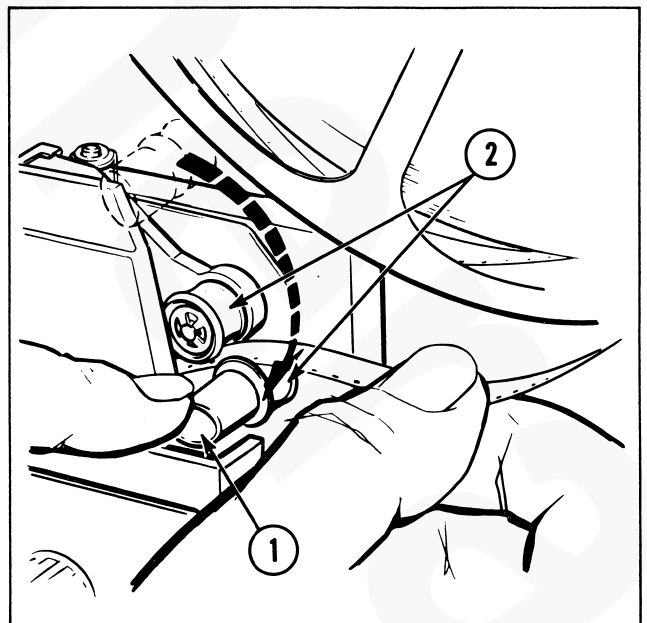

Figure A. Autoload Threading

SERVICE INSTRUCTIONS

During reassembly, be sure to lubricate parts as noted in the service instructions. If possible, use only recommended Bell & Howell lubricants as listed below. If Bell & Howell lubricants are not immediately available, use only the best grades of ball bearing grease

and projector oil obtainable from local commercial outlets.

Grease (Bell & Howell Specs. 1516 and 1956)
Oil (Bell & Howell Spec. 1543)

BRISTOL SETSCREW WRENCHES REQUIRED FOR MAINTENANCE

Setscrew Size	No. of Flutes	B & H Part Number	
		Handle	Wrench
No. 4-40NC	6	G1271-F1	G1271-X2
No. 6-32NC	6	STK3852-B	STK3863-B
No. 8-32NC	6	G165-F1	G165-X2

NOTE: Wrench G165-F3 is required to tighten setscrew in tool handles.

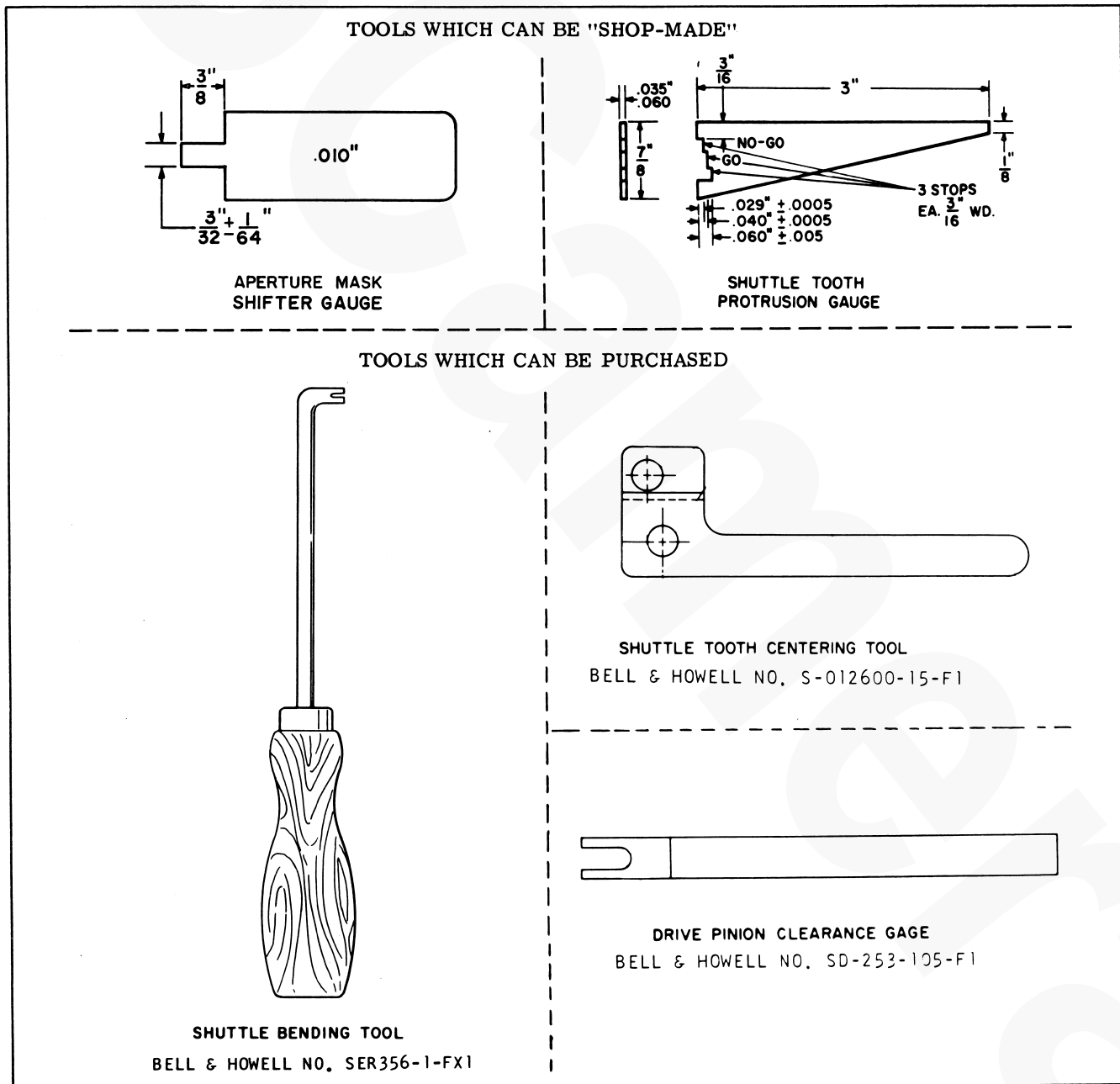

Figure B. Special Tools

Trouble Shooting

TROUBLE	PROBABLE CAUSE	REMEDY
Projector inoperative with switch in the MOTOR or LAMP position.	<ol style="list-style-type: none"> 1. No electrical power. 2. Loose motor pulley. 3. Broken drive belt. 4. Defective switch or wiring. 	<ol style="list-style-type: none"> 1. Check power source. 2. Tighten pulley setscrew. 3. Replace belt. 4. Check switch and circuitry.
Picture flicker.	<ol style="list-style-type: none"> 1. Drive roller assemblies not adjusted properly. 2. Defective drive belt pulley. 3. Dirt, wear or binding in gearing. 	<ol style="list-style-type: none"> 1. Readjust as instructed in paragraph 21. 2. Replace drive belt pulley. 3. Clean and repair or adjust gearing as instructed in reassembly instructions.
Film scratches.	<ol style="list-style-type: none"> 1. Excessively dirty film channel parts (rollers, guides, etc.). 2. Worn pressure and aperture plates (66 and 69, Figure 4). 3. Worn or damaged film guide rail (67, Figure 4). 	<ol style="list-style-type: none"> 1. Clean projector thoroughly. 2. Replace if worn or marred. 3. Replace film guide rail.
Jumpy picture.	<ol style="list-style-type: none"> 1. Loss of film loop due to damaged film. 2. Green film. 3. Shuttle tooth worn. 4. Misaligned shuttle tooth. 5. Grooves worn in film guide rail (67, Figure 4). 6. Upper and/or lower loopformer binding. 	<ol style="list-style-type: none"> 1. Inspect and splice as required. 2. Run film through projector two or three times to age the film. 3. Replace shuttle assembly. 4. Adjust and align shuttle as instructed in paragraph 19. 5. Replace film guide rail. 6. Free up binding loopformer.
Soft focus.	<ol style="list-style-type: none"> 1. Dirty projection lens. 2. Lens mount out of alignment. 3. Loose lens mount catch. 	<ol style="list-style-type: none"> 1. Clean projector lens. 2. Readjust focus screw as necessary. 3. Reset tension by bending catch carefully.
Autothreading not operating properly.	<ol style="list-style-type: none"> 1. Fire shutter binding and not allowing film to pass. 	<ol style="list-style-type: none"> 1. Free up fire shutter.
Fails to take-up or rewind.	<ol style="list-style-type: none"> 1. Defective drive belt. 2. Worn rim on drive roller. 	<ol style="list-style-type: none"> 1. Replace belt. 2. Replace roller.

SERVICE INSTRUCTIONS

TROUBLE	PROBABLE CAUSE	REMEDY
Fails to take-up or rewind. (Cont)	3. Drive rollers not adjusted properly.	3. Readjust as instructed in paragraph 21.
	4. Defective spindles.	4. Replace spindle.
Noisy.	1. Loose attaching parts.	1. Tighten as necessary.
	2. Gearing dry.	2. Lubricate as necessary.
Dim projected pictures.	1. Projector lamp dirty.	1. Clean lamp.
	2. Wrong lamp used.	2. Use type DJL 120 V, 150 W lamp only.
	3. Lamp socket out of alignment.	3. Align lamp socket as instructed in paragraph 18.
Format shifter not operating properly.	1. Aperture mask not shifting when changing format.	1. Adjust mask actuating bracket.
	2. Format shifter stop eccentrics not adjusted properly.	2. Readjust eccentrics as instructed in paragraph 22.
Image not centered over aperture mask opening.	1. Aperture mask eccentric not properly adjusted.	1. Readjust eccentric.
Projector not framing properly.	1. Lens mount loose on framing shaft.	1. Readjust upper or lower locking collar as instructed in paragraph 20.
	2. Framing collar not properly positioned on shaft.	2. Readjust framing collar.

Disassembly

1. GENERAL DISASSEMBLY INSTRUCTIONS.

a. Before beginning the disassembly procedure, be sure to disconnect the projector from the power source and remove the projection lamp and lens. Wrap the lamp and lens in tissue paper and place them on a shelf to protect them from possible damage.

b. If repairs require the replacement of electrical items (lamp socket, motor, or switch), refer to the wiring diagram at the end of the Parts Catalog as an aid to wire identification and unsolder or disconnect wires as necessary.

c. When removing riveted parts for replacement, the old rivet must be drilled out of the casting. Use a drill equal to, or slightly smaller than, the diameter of the rivet to be removed.

d. When attaching parts (screws, nuts, etc.) are removed, reassemble them loosely to the removed part or to the tapped casting to prevent loss.

2. REMOVAL OF PARTS IN FIGURE 1. Remove parts, as necessary, in their indexed order of disassembly, noting the following special precautions.

a. The back cover (21) is secured by six screws. Four of these screws (9) are inserted through the mechanism plate and into tapped bosses in the cover; the remaining two screws (10) are inserted up through the base and into tapped bosses in the cover. To remove the back cover completely, disconnect the power cord leads from the crimp connectors.

3. REMOVAL OF PARTS IN FIGURE 2. Remove parts, as necessary, in their indexed order of disassembly, noting the following special precautions.

a. Note that the air deflector (4) is secured to the base casting with one screw (3A) while the remaining two screws (3) attach it to the lamp socket assembly (10). If the lamp socket is to be removed, take out the single screw (3A) and the two lamp socket rivets and remove the socket with deflector attached. If the lamp socket need not be removed, remove only the single screw (3A) so that the deflector can be raised to expose the motor and blower fan for inspection.

b. The conversion knob (11) must be pulled off and nameplates (15 and 16) must be pried off to permit removal of screws (17) for the replacement of switch (20). The control housing is secured to the mechanism plate from the motor side by two screws (12) which are inserted into tapped holes in the control housing.

c. A retaining ring (23) retains the guide roller (24) on the roller shaft (28). Removal of a second retaining ring (23) will permit the withdrawal of the plastic threading guide (25), spacer (26) and torsion spring (27). Note the manner in which the bent ends of the spring (27) engage holes in the mechanism plate and spacer.

4. REMOVAL OF PARTS IN FIGURE 3. Remove parts, as necessary, in their indexed order of disassembly, noting the following special precautions.

a. Removal of four screws (1) and two screws (2) will permit withdrawal of both the reel arms (3) and the assembled spindles (5). Do not disassemble the reel spindle assemblies.

b. Spur gears (6) and (7) can be lifted from the studs of the stud and support assembly (24). To free spur gear and shaft assembly (14), loosen setscrew (12) in the spur gear (13) and disassemble these parts from the support assembly. To free spur gear and shaft assembly (11) loosen setscrew (9) in spur gear (10) and disassemble these parts from the support assembly.

c. Two small spur gears (16) and two large spur gears (17) are retained on the studs of gear mounting plate by retaining rings (15). Note that spring tension washer (18) is located beneath the large gear which is closest to the take-up arm gear shaft.

d. The removal of a single screw (19) and two retaining rings (20) will permit the gear mounting plate assembly (24) and all remaining reel arm parts to be disassembled from the mechanism plate.

5. REMOVAL OF PARTS IN FIGURE 4. Remove parts, as necessary, in their indexed order of disassembly, noting the following special precautions.

a. Before disassembling the film drive roller and shaft assembly and loopformer parts, note carefully

the manner in which the gear retaining spring (3) and spring ratchet (4) are installed so that they can be re-assembled in the same manner. Carefully remove the spring (3) and disassemble parts (4 through 8) from the rear of the film drive roller and shaft assembly.

b. To remove lens carrier assembly (73), loosen one setscrew (11) and remove framer knob (12) from shaft (13). Swing open lens carrier assembly (73), loosen three setscrews (11) in collars (14 and 15) and unscrew shaft (13) from mechanism casting.

c. When removing lower loopformer (22) and upper loopformer (41) from mechanism casting, note the manner in which the parts were disassembled to insure proper reassembly.

d. If the aperture plate parts (65 through 71) are removed, note carefully the manner in which side tension spring (65) and arm (66) are assembled to insure proper reassembly.

6. REMOVAL OF PARTS IN FIGURE 5. Remove parts, as necessary, in their indexed order of disassembly, noting the following special precautions.

a. To remove the lens carrier from the mechanism casting refer to paragraph 5.

b. Remove the setscrew from the focus knob (1) and pry the knob from its shaft. Pry off the trim plate (2) and remove parts (5 through 9), and remove two screws (3). Inspect the O-ring (7) for damage or dryness and hardness and replace if necessary.

c. The pressure plate and stud assembly (15) can be removed from the lens mount (10) without disassembling the mount from the mechanism casting. Swing open the lens carrier cover and remove the retaining E-rings (13). Remove the pressure plate parts.

7. REMOVAL OF PARTS IN FIGURE 6. Remove parts, as necessary, in their indexed order of disassembly, noting the following special precautions.

a. Loosen setscrews (33) and (35) so that the drive pinion (34) and manual knob (36) are loose on the main shaft. Pry retaining ring (37) from its groove in the main shaft and press the shaft toward the rear of the projector until the manual knob can be slipped from the shaft; then withdraw the shaft toward the front of the projector, removing the drive pinion (34) and friction washer (39) in the process.

8. REMOVAL OF PARTS IN FIGURE 7. Remove parts, as necessary, in their indexed order of disassembly, noting the following special precautions.

a. Rest the projector base on its side to expose the motor mounting screws (11) which tap into the threaded inserts (12). Support the motor (20) while removing the screws, and lift out the motor with fans (9) and (10) installed. The brackets (18) and (19) need not be disassembled unless the motor is in need of replacement.

Reassembly and Adjustment

9. GENERAL.

a. When the reassembly procedure includes the staking of rivets or other parts, all such riveting and staking should be accomplished before any other reassembly procedures are attempted. Be sure to support the casting or plate solidly while performing the riveting or staking operation.

b. Be sure to follow the lubrication procedures indicated in the reassembly instructions, using the Bell & Howell lubricants noted in the chart at the end of this section. Lubricate sparingly and wipe away excess lubricant with a lint-free cloth.

c. When installing electrical parts (motor, switch or lamp socket), refer to the wiring diagram at the end of the Parts Catalog for proper wiring connections.

10. REASSEMBLY OF PARTS IN FIGURE 7. Reassemble parts in reverse order of disassembly, noting the following special precautions.

a. To completely assemble the film cutter to the base, first place the spacer (30) onto the base with the pointed end toward the post of the base. Next place the film cutter (29) over the spacer with the formed end toward the post of the base, and add the film cutter guide (28) with lettering up and pointed end toward the post of the base. Secure to the base with two rivets (27).

b. When assembling rubber foot (26) to base, note that counterbore of foot must be away from the base and that the rivets must be inserted down through the base and the feet.

c. Motor parts should be preassembled as follows: Assemble the grommets (14) into the motor mounting brackets (18) and (19) and the inserts (12), with washers (13), into the grommets. Insert screws (17) through holes in the short bracket (19); then through the motor (20) and finally through the holes in the long bracket (18). Install and tighten the two nuts (15) and washers (16). Assemble the fan and hub assembly (9) onto the long end of the motor shaft with fan hub away from the motor. Secure fan to the motor shaft with setscrew (8).

d. Position the motor on the base and align the holes in the base with the holes in the mounting inserts (12), being careful not to damage the blades of the blower fan against the cast wall of the blower housing. Install and tighten the three motor bracket screws (11). Secure the motor fan (10) at the opposite end of the motor shaft.

e. Assemble drive pulley (7) onto the long end of the motor shaft with hub away from the motor. Center the groove of the pulley over the wall of the blower housing. Secure the pulley to the shaft with setscrew (6).

f. Install the main plate assembly (2) onto base assembly against the mounting uprights just behind the film guide groove in the base. Secure main plate to the base with three screws (1).

11. REASSEMBLY OF PARTS IN FIGURE 6. Reassemble parts in reverse order of disassembly, noting the following special precautions.

a. Assemble the friction washer (39) to the main shaft (38) and lightly oil the rear end of the shaft. Insert end of shaft through the bearing in the short cast arm of the mechanism plate, assemble the drive pinion (34), hub to the right, to the shaft, and insert the shaft through the bearing in the long cast arm. Press the shaft toward the rear of the mechanism plate until the front end of the shaft clears the cut-out at the front edge of the mechanism plate. Hold the manual knob (36) in this cut-out and slide the main shaft forward until it engages the knob. Tighten the knob setscrew just enough to hold, and assemble the retaining ring (37) to main shaft groove so that the friction washer (39) is captured against the bearing in the short cast arm. Temporarily tighten the drive pinion setscrew (33) just enough to hold.

b. Tap the knob end of the main shaft with a mallet to seat the retaining ring (37) flush against the knob side of the recess wall. Assemble the thrust washer (32) onto the main shaft. Note that one face of the pull-down cam (31) has an identification dot (shallow indent). Install the cam on the main shaft with this dot facing the main shaft knob. Position the cam so that the identification mark (Figure C) is at the bottom, below the main shaft. Dip the setscrew (30) in shellac and insert

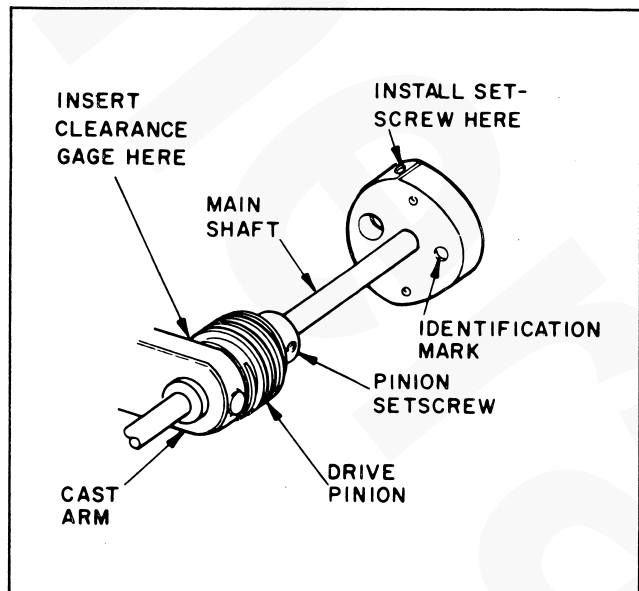

Figure C. Installing Pull-Down Cam and Drive Pinion

it into the setscrew hole. Tighten the setscrew securely, and wipe excess shellac from surface of cam.

c. Loosen setscrew (35) in the manual knob (36) and visually center the knob in the main plate cut-out. There must be sufficient clearance on either side of the knob to eliminate any binding of the knob against the main plate. Tighten the setscrew (35) securely and turn the main shaft. The shaft must turn freely with no binding or high spots. If binding does occur, tap the shaft lightly to free it.

d. Grease both sides of washer (25) and assemble the washer to the pivot screw (23) with the bowed face against the shoulder of the screw. Assemble the shuttle and framer lever assembly over screw and add spacer (28) over the end of the screw. Assemble to projector engaging stud of bracket (26) with notch of format shifting bracket and the threaded end of the screw through the hole in the mounting bracket. Loosely secure the parts to the bracket with one nut (24).

e. Lightly grease the pull-down cam (31) where the shoes will make contact. With the shuttle and pull-down cam in a horizontal position, insert the cam shoes (29) between the cam and the shuttle openings. Note that any combination of cam shoes may be used to obtain the proper fit. Turn the manual knob one full revolution in both the clockwise and counterclockwise direction; fit must be snug without binding. If too loose or too tight, correct the condition by selecting a suitable combination of cam shoes. Then finish securing the shuttle to the mechanism plate by tightening the Sems nut (24) securely.

f. Install the in-out cam (22) so that its holes line up with those in the pull-down cam and the high section of its rim is toward the shuttle. Add the shutter (21) with the open side of the shutter away from the cams and the two screw holes lined up with those in the cams. Install the shutter washer (20), align all holes, and install the two screws (19). Before tightening the screws, hold the manual knob firmly and remove excess play in the in-out cam, shutter and washer by rotating these parts counterclockwise against the two screws; then tighten the screws securely. Turn the manual knob in both directions to make certain that all parts rotate freely and without binding. Now remove the drive pinion setscrew (33) and insert the drive pinion clearance gage (Figure B) between the drive pinion and the face of the bearing in the short cast arm. Rotate the main shaft until the manual pull-down cam is at the position shown in Figure C; then rotate the drive pinion until its setscrew hole is aligned with the identification mark on the pull-down cam. Dip the setscrew in shellac and, while pressing the drive pinion and manual knob toward one another, install and tighten the setscrew securely. Remove the clearance gage.

g. Lightly grease the studs of the pulley mounting bracket and install a washer (14) on each stud. Apply a light film of grease to each stud and install the drive rollers (15) and remaining washers (14) to the studs, securing these parts with the retaining rings (13). Check to make sure that the rollers spin freely and

smoothly. Assemble the spring loading bracket assembly (18) to the pulley mounting bracket assembly with the two screws (17). Line up the edges of both brackets and tighten the screws enough to hold. Lightly oil the end of the pulley mounting bracket shaft and insert the shaft through the bearing hole in the safety shutter assembly, with the ear of the actuating plate between shoes of the drive pulley assembly. One drive roller must be on each side of the shutter pulley. Install a retaining ring (11) to secure pulley mounting bracket and engage the drive belt with the motor pulley and the two drive rollers.

h. Assemble the safety shutter assembly (10) to the projector. The safety shutter must locate on shoulder of pivot stud (7) with the front end of the assembly inserted through the mechanism plate. Install screw (8) into pivot hole of mounting plate of fire shutter assembly. Hold fire shutter assembly flat to keep screw from falling out, and position spring (12) over the shoulder of the pivot screw. Turn the screw tightly into the tapped hole of the pivot stud. Cross the legs of the spring and engage them in the slotted ears of the safety shutter bracket. Secure the front end of the safety shutter by installing and tightening screw (9). Move the forward-reverse lever through all three positions to make certain that the lever moves freely and locks in each position. Place the lever in the "still" (center) position and visually check the centering of the perforated heat filter with the aperture opening. Adjust for centering and minimum amount of play by bending the legs of the pivot spring and moving safety shutter mounting plate up or down as necessary.

12. REASSEMBLY OF PARTS IN FIGURE 5. Reassemble parts in reverse order of disassembly, noting the following special precautions.

a. Assemble lens carrier parts as follows: Grease recess of shaft and assemble washer (7) over end of shaft. Assemble focus shaft and pin assembly (8) into hole of lens carrier (10), and place spring (6) over focus shaft. Secure focus shaft to lens mount with retaining ring (5). Assemble springs (14) over the studs on the pressure plate and stud assembly (15) and secure to the lens carrier with retaining rings (13) with longest rail toward mounting ears of lens carrier. Retaining rings must be assembled straight in from end of casting to avoid interference.

CAUTION

Do not distort pressure plate when assembling. When holding in, press only in the area at the staked ends of the studs.

Assemble cover plate (12) to lens carrier and loosely secure with two screws (11). Assemble lens carrier cover (4) to lens carrier using shim washers (9) between cover and lens carrier. Shims are to be used in pairs; as required, to maintain a minimum clearance of 0.005 between lens carrier cover and loopformers, without binding. Tighten previously assembled screws (11).

SERVICE INSTRUCTIONS

13. REASSEMBLY OF PARTS IN FIGURE 4. Reassemble parts in reverse order of disassembly, noting the following special precautions.

a. Assemble the fire shutter tension spring (68) to recess of fire shutter pivot stud. Short end of spring is to be engaged with fire shutter actuating ear and long end is to be hooked over side tension arm (66). Actuate ear of fire shutter and release slowly several times to check proper operation of shutter. Shutter must return to stop on framing bracket without binding.

b. Place aperture plate (69) on the work bench with the stud up and away from you. Assemble the side tension arm (66) over the stud with the tension arm prongs down and into the aperture plate slots. Assemble the spring (65) with the center loop toward you and the ends of the spring entering the holes in the side tension arm. Place the loop opening of the spring into the stud groove and press the spring in until it seats. Side tension arm should exert a tension of 160 grams minimum to 180 grams maximum. It may be necessary to adjust the side tension spring (65) as shown in Figure D until the proper tension is obtained. Then assemble the aperture plate loosely to the mechanism plate with the two screws (64). Line up the aperture opening and tighten the two screws securely. Assemble the guide rail (67) to the aperture plate. Position the guide rail over the threaded studs, and while holding the guide rail in, with tangs against the inside edge of the slots in the aperture rail and aperture plate, secure the guide rail with two screws (64). After the aperture plate screws are tightened, unhook fire shutter tension spring (68) from ear of the side tension arm (66). Place free end of spring (68) between rear of side tension arm and mechanism plate.

c. Pick up shaft (53) and assemble one retaining ring (51) to groove at either end of the shaft; then from the other end of the shaft assemble spring washer (52) with bow up. Assemble spring (54) over shaft and place two upper spring stop plate and sleeve assemblies (55) over the spring and shaft. Assemble shim washer (74) over shaft. Assemble spring (56) over shaft and com-

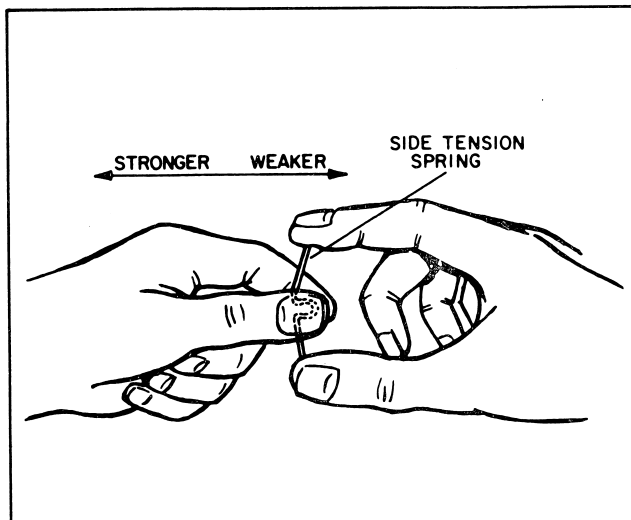

Figure D. Adjusting Tension of Aperture Plate Spring

plete assembly by inserting a second retaining ring (51) to groove of shaft.

d. Assemble spring (49) over snubber pivot bushing with straight end of spring into the shear formed notch of upper loopformer mounting plate. Liberally apply oil to the pivot shaft (48), assemble into bushing of mounting plate and secure at rear side with retaining ring (47). Snubber must pivot freely without binding and the spring must return snubber arm to the running position. Apply light coating of grease to the actuating shaft of snubber arm and assemble tension spring (46) over the shaft. Then assemble washer (45) and roller (44) over the shaft. Secure the assembly to shaft with one retaining ring (43). Assemble the threading knob assembly (42) to the snubber arm shaft with the flat of the knob over the flat of the shaft. Press knob firmly onto the shaft to seat.

e. Apply a light coating of grease to two roller shafts of upper loopformer. Place guide roller (40) over the right shaft of the loopformer and roller (39) over the left shaft of the loopformer, both with recess up. Assemble two washers (38), one over each shaft, to the loopformer. Secure rollers with two retaining rings (37). Rollers must not have excessive end play and must be free of binding. Position upper film guide (35) against the mounting plate and loosely secure with one screw (34). Film guide will be final tightened after assembly to the mechanism plate. Assemble one washer (25) to shaft of upper loopformer assembly, and liberally apply oil to the shaft. Insert the loopformer shaft into the bushing of the mounting plate, engaging tabs of loopformer between the spring loaded shoes of the mounting plate. Place a .002 shim between loopformer and bearing washer. Place locking collar (24) over the rear of the shaft. Secure the collar with two setscrews (23). Secure the upper loopformer assembly to the mechanism plate with two screws (16). Do not fully tighten these screws. Assemble one screw (16) from inside of mechanism plate through the aperture plate and into the upper film guide. Tighten two previously assembled screws (16) to complete assembly of upper loopformer assembly. Actuate loopformer up and down to assure free operation. Assembly must be free from binding in either direction.

f. Place bumper (32) onto the inner side of the lower tab of the plate (33); holes in bumper and plate must line up. Assemble one retaining ring (27) to the groove at one end of shaft (29); then from other end of shaft assemble spring washer (28) with bow up. Assemble spring (30) and plate (31) over the shaft. Then insert second spring washer (28) over the shaft with bow down. Assemble remaining retaining ring (27) to other end of shaft to complete the assembly.

g. Apply a light coat of grease to the roller shafts of the lower loopformer. Assemble two rollers (21) to the lower loopformer (22) with recess up and add two washers (20), one over each shaft, into the roller recess. Secure rollers to shafts with two retaining rings (19). Secure lower film guide (17) to edge of mounting plate with one screw (16). Oil the shaft of the loopformer and roller assembly and add one washer (25) to the shaft. Insert the lower loopformer shaft into the bushing of mounting plate (33), engaging the tabs of

loopformer between lower stop plate and bumper. Place a .002 shim between loopformer and bearing washer. Assemble collar (24) to the shaft and secure with two setscrews (23). Secure lower loopformer assembly to the mechanism plate with two screws (16) while holding the loopformer assembly against aperture plate. Actuate loopformer to assure free operation. Assembly must be free from any binding.

h. Assemble shaft (13) through collars (14 and 15) into lens carrier (73). Adjust collars (14 and 15) on shaft as instructed in paragraph 21, Figure G. Secure collars with three setscrews (11). Secure framer knob (12) to shaft (13) with one setscrew (11).

i. Assemble washer (10) over the end of drive roller and shaft assembly (9) and oil the end of the shaft. Lightly oil gears (8) and (6). Assemble gear (8) to the drive roller shaft and place drive gear lever and stud assembly (7) over this gear. Assemble gear (6) and spacer (5) to the shaft. Add ratchet spring (4) to the shaft with depressions engaged with gear teeth. Assemble spring (3) to shaft with the short end of the spring engaged in the slot on the shaft. Apply light film of grease to the remaining stud on the gear plate and assemble gear (2). Secure with retaining ring (1).

14. REASSEMBLY OF PARTS IN FIGURE 3. Reassemble parts in reverse order of disassembly, noting the following special precautions.

a. Insert bearings (21) through holes in supply and take-up arms (23) from the unpainted sides of the arms. Apply grease to both arms around bearings. Add a steel ball (28) on either side of each bearing. Add cam (26) over the bearing of the supply arm and cam (27) over the bearing of the take-up arm with prongs toward top of main frame. Install tension springs (25) over the bearings, small diameter down and end of small diameter toward top of mechanism plate. Assemble the gear mounting plate (24) and install the two large retaining rings (20) to secure all parts. Secure the gear mounting plate to the main plate with the single screw (19).

b. Lightly oil the end of the spur gear and shaft assemblies (11) and (14) and assemble one shaft into the supply arm bearing and one shaft into the take-up arm bearing from the arm side. Assemble spur gear (10) over end of gear shaft. Insert a 0.003 shim between gear face and bearing face, press down lightly on the spur gear, and tighten its setscrew (9) securely. Check to make certain that the assembled spur gear and gear and shaft assembly have 0.002 to 0.003 inch end play. Repeat the above procedure with the take-up gear shaft assembly (14) and its spur gear (13) and setscrew (12).

c. Lightly grease each gear stud of the gear mounting plate (24). Install one spur gear (16) onto its gear stud so that it meshes with the supply arm spur gear (10). Install second spur gear (16) onto its gear stud so that it meshes with the take-up spur gear (13). Secure both gears with the retaining rings (15). Assemble the large spur gears (17) on their studs with a spring tension washer (18), bowed side down, beneath the gear closest to the take-up arm.

d. Lightly grease all gear studs of the reel arm supports (23). Assemble one gear (7), hub down, onto its stud on the supply arm and the other gear (7) onto its

stud on the take-up arm, also with hub down. Add four gears (6), with hubs down, on the two remaining studs of both arms. Lightly grease all gear teeth and carefully assemble the reel arms to the supports, installing and tightening the screws (1 and 2).

15. REASSEMBLY OF PARTS IN FIGURE 2. Reassemble parts in reverse order of disassembly, noting the following special precautions.

a. Assemble forward-reverse knob (37) to reversing lever with lettering positioned so as to be readable, and secure with the screw (36).

b. Assemble screws (29) to rollers (31 and 32), with head of screw in recess of roller, and install to the upright of the base. Assemble the film deflector (33) over the threaded end of the upper screw so that it fits into the formed recess and secure in place with hex nut (30).

c. Install the torsion spring (27), short tang first, over the idler stud protruding from the mechanism plate. Engage the short tang of the spring with the hole in the mechanism plate. Install spacer (26) and guide (25) over the stud and the long tang of the spring and secure these parts with retaining ring (23). Assemble roller (24) to stud and secure with the second retaining ring (23).

d. Assemble nut (22) and screw (21) to the control housing (13). Check and adjust gap between nut and underside of screw head with shim of 0.047. Apply grease to all surfaces of the interlock plate (19) which will contact the control housing (13). Assemble end of plate with elongated slot through notch in center wall, with angled edge toward top of control housing. Place two spacers (18) on the assembly. Assemble switch (20) onto the control housing with notch side of switch toward top of control housing. Secure switch to housing with two screws (17). Actuate the switch to assure switch and interlock plate are working properly. Assemble sleeve (14) over the three switch leads and slide down as close as possible to rear of switch assembly. Apply lamp designation label to shelf of control housing approximately 1/8 inch in from front edge and centered in other direction. Smooth down label (38) to assure good adhesion using clean dry rag. Place the control housing (13) onto the main plate with format shifting shaft of main plate through long rectangular opening of control housing. Secure the assembly to main plate with two screws (12). Press format shifting knob (11) onto protruding shaft through control housing.

e. Pull lead wires of lamp socket and bracket assembly through clamp (9), and assemble clamp to main plate with screw (7) and washer (8). Secure lamp socket assembly (10) to main plate with two screws (5) and washers (6). Attach lead wires to lamp socket assembly as shown in the wiring diagram, Figure 8. After the projector is assembled, the lamp socket must be aligned as instructed in paragraph 17. Secure the fan shield (4) to the lamp socket bracket with two screws (3). Bend the end of the fan shield down around the fan and secure it to the blower well with screw (3A). Dress the leads and pull them up snugly so they do not touch the motor.

SERVICE INSTRUCTIONS

16. REASSEMBLY OF PARTS IN FIGURE 1. Reassemble parts in reverse order of disassembly, noting the following special precautions.

a. Assemble the lamphouse air baffle (24), spacer (25) and catch (26) to the lamphouse (27) with one rivet (23). Do not install the assembled lamphouse assembly (22) until the lamp socket is aligned.

b. Insert cover release button (4) into top hole of front cover (8). Add catch plate (3) onto button with bulge up and rivet together with rivet (2).

17. FINAL INSPECTION.

a. Open the film gate and manually rotate the main shaft knob while watching the movement of the shuttle. The shuttle tooth should travel in the center of the shuttle slot. If necessary, bend the shuttle carefully to insure that the shuttle tooth does not touch either side of the slot. (Refer to paragraph 18.)

b. With the projector grounded, plug the line cord into the 110 to 120 volts outlet. With the off-motor-lamp switch in the motor position, run the projector in "forward" while applying grease to the gear train with a brush. Be very careful not to get grease on the drive belt or the motor pulley. After greasing and with the projector still running, apply naphtha to the drive belt and pulley with a brush to remove any grease or oil from these parts; then blow dry with a low-pressure jet of compressed air.

c. With the lens removed, film gate open and projector running in forward direction, move the forward-reverse lever to "still" (center) position. The safety shutter must drop in front of aperture opening at the very moment that the motor stops running. Repeat the same check by moving the forward-reverse lever to "reverse" position and then to "still" position. At the same time, check to make certain that the mechanism (drive rollers and sprockets) begin to drive just before the safety shutter clears the aperture opening. Turn off projector and, if necessary, adjust safety shutter operation as instructed in paragraph 20.

d. With the film gate closed, check to make certain that there is no play in the lens carrier. If necessary, bend the lens carrier spring catch with a pliers to eliminate play.

e. Check all attaching screws and nuts to make certain that they are tightened securely and visually check the projector for missing parts. Pick up the unit, turn it over and shake it to make sure no loose parts are lying in the mechanism.

f. Check to make sure that all lead wire connections are secure by tugging gently on the lead wire near the terminal connection, and see that all leads are properly dressed out of the way of moving parts.

g. Make final projector adjustments as outlined in paragraphs 16 through 20. Then make a final test of projector operation as outlined in the Final Test section.

18. CHECKING SPINDLE TORQUE.

a. The spindle assembly on the front (rewind) arm must be replaced if (1) Film spills from the reel which indicates that the spindle is too loose, or (2) If the projector pulls film from the reel or the perforations on the film are damaged. This would indicate that the spindle is too tight.

b. The spindle assembly on the rear (take-up) arm must be replaced if (1) The reel will not take up the film which is an indication that the spindle is too loose, or (2) If it pulls bottom loop out or damages film perforations or causes picture unsteadiness.

19. LAMP SOCKET ALIGNMENT. As illustrated in Figure E, the lamp socket is secured with two screws. The screw to the rear of the lamp socket is inserted through an over-sized hole in the main plate; thus, when both screws are loosened slightly, the socket can be rotated to obtain full and even light through the aperture opening.

a. Rotate the manual knob until the shutter clears the aperture opening. Install the projection lamp, aligning the key on the lamp base with the key slot in the socket and pressing down firmly on top of lamp until it is seated.

b. Install the projection lens and switch on the projector. Focus the lens until the image of the aperture is sharp on the screen and note whether a dark area is evident at the top or bottom of the image.

c. If dark area was noted, switch off the projector and loosen the lamp socket screws just enough to permit the lamp socket to be rotated. A dark area at the top of the aperture image indicates that light is projecting at a slightly downward angle. With the blade end of a screwdriver, apply a slight amount of pressure against the top edge of the rear socket counterclockwise.

d. If the dark area appeared at the bottom of the aperture image, it indicates that the light is projecting at a slightly upward angle. In that case, apply pressure to the bottom edge of the rear socket screw, rotating the lamp socket clockwise.

e. It may be necessary to repeat the adjustment several times, switching on the lamp between adjustments to check the image. When the aperture image appears fully and evenly lighted, tighten both lamp socket screws securely, watching the image to make certain that the socket does not move out of alignment. Then switch off the projector and install the lamphouse.

20. SHUTTLE TOOTH ADJUSTMENT. Excessive or inadequate protrusion of the shuttle teeth will result in improper film transport during operation. Proper shuttle tooth protrusion is checked with the shuttle tooth Go-NO-Go gage shown in Figure B. Proceed as follows.

a. Set the framer knob at the approximate center of its travel range, shuttle in standard 8-mm format, and swing open the lens carrier.

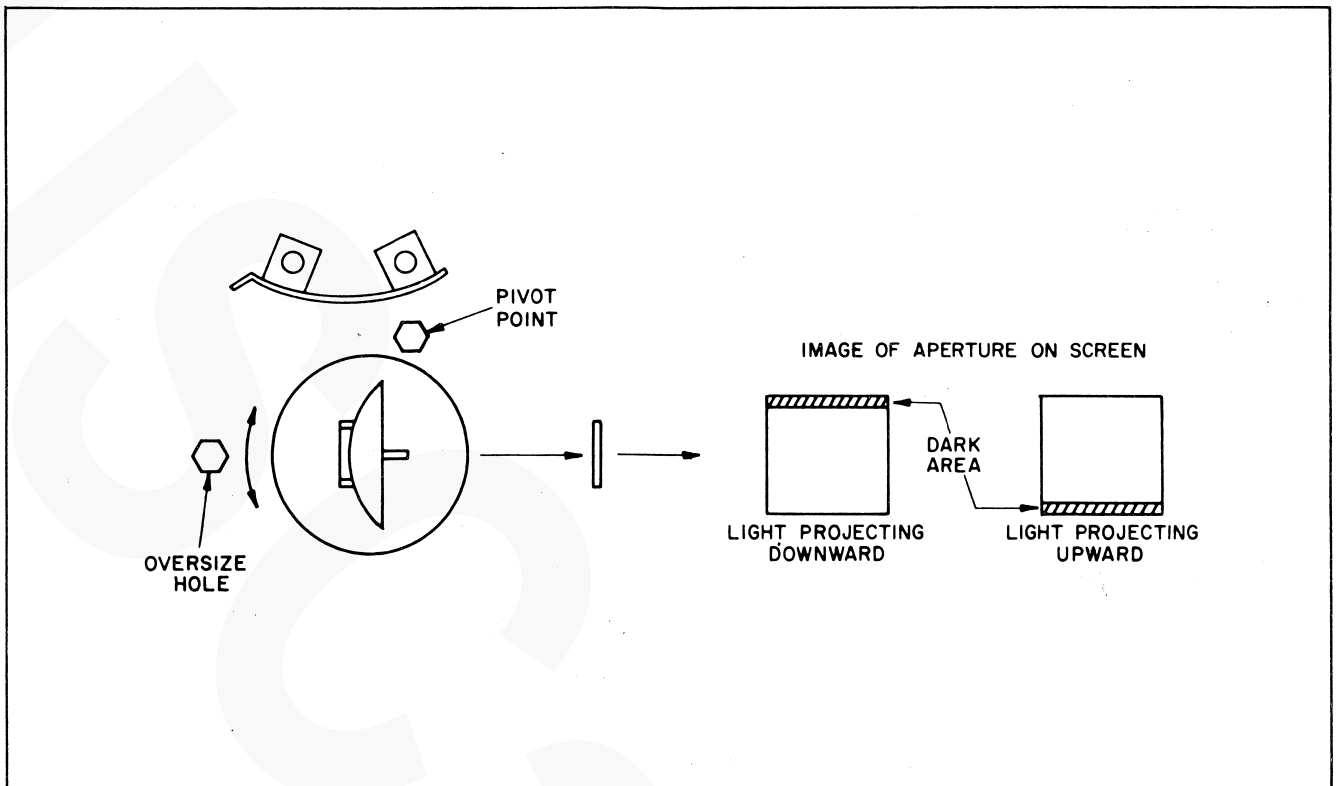

Figure E. Lamp Socket Alignment

b. Rotate the main shaft knob until the shuttle teeth reach the approximate center of the downstroke.

c. Place the notched edge of the shuttle protrusion gage against the aperture plate with the deepest notch positioned directly over the shuttle teeth.

d. While holding the gage lightly but firmly against the aperture plate, slide the gage slowly downward. If the shuttle teeth catch against the "go" step of the gage, the teeth are protruding too far beyond the surface of the aperture plate. If the teeth pass the "go" step of the gage but fail to catch against the "no-go" step, the teeth are not protruding far enough. Also, note if shuttle teeth are protruding an equal amount.

e. To adjust shuttle tooth protrusion, remove the lamphouse and lamp and rotate the manual knob until the shuttle teeth are at the center of the down stroke. Insert the shuttle bending tool through the opening in casting, just forward of the lamp socket, and engage the slot of the tool with the shuttle tooth arm. Note, in Figure F, that the bending tool should engage the arm on the annealed (shiny) area. To increase the height of shuttle teeth above the aperture plate surface, move the handle of the tool away from the projector main plate; to decrease height, move handle toward main plate. If shuttle teeth are protruding unevenly (one tooth protruding more than the other), the bending tool can be raised or lowered, thereby twisting the shuttle tooth arm slightly.

CAUTION

The shuttle tooth arm must be bent carefully, and in small amounts, checking between each bending operation until shuttle tooth height is properly established. Use extreme caution when bending so as not to distort aperture plate components or damage the shuttle teeth.

f. On the early models, carefully rest the projector on its back surface (lens pointing up) with the format shifter locked in super 8-mm position. Open the lens carrier and set the framer knob at the approximate center of its travel range. Place a strip of film onto the aperture plate and turn the manual knob until the shuttle teeth are at the extreme top and extending through the film. With a magnifying glass, check to make certain that the teeth are approximately in the center of the perforations. To adjust centering, refer to Figure F, and loosen the screw (1) and hex nut (2), leaving hex nut (3) tight. Engage the 3/8 inch diameter holes of the shuttle tooth centering tool (Figure B) with the two hex nuts (2) and (3) and while viewing the shuttle teeth, move the handle up or down until shuttle teeth are centered. Tighten the screw (1) and then hex nut (2) to lock the adjustment.

g. On later models, the procedure is the same as outlined in paragraph f. However, adjust centering as necessary by loosening screw in adjusting slot and

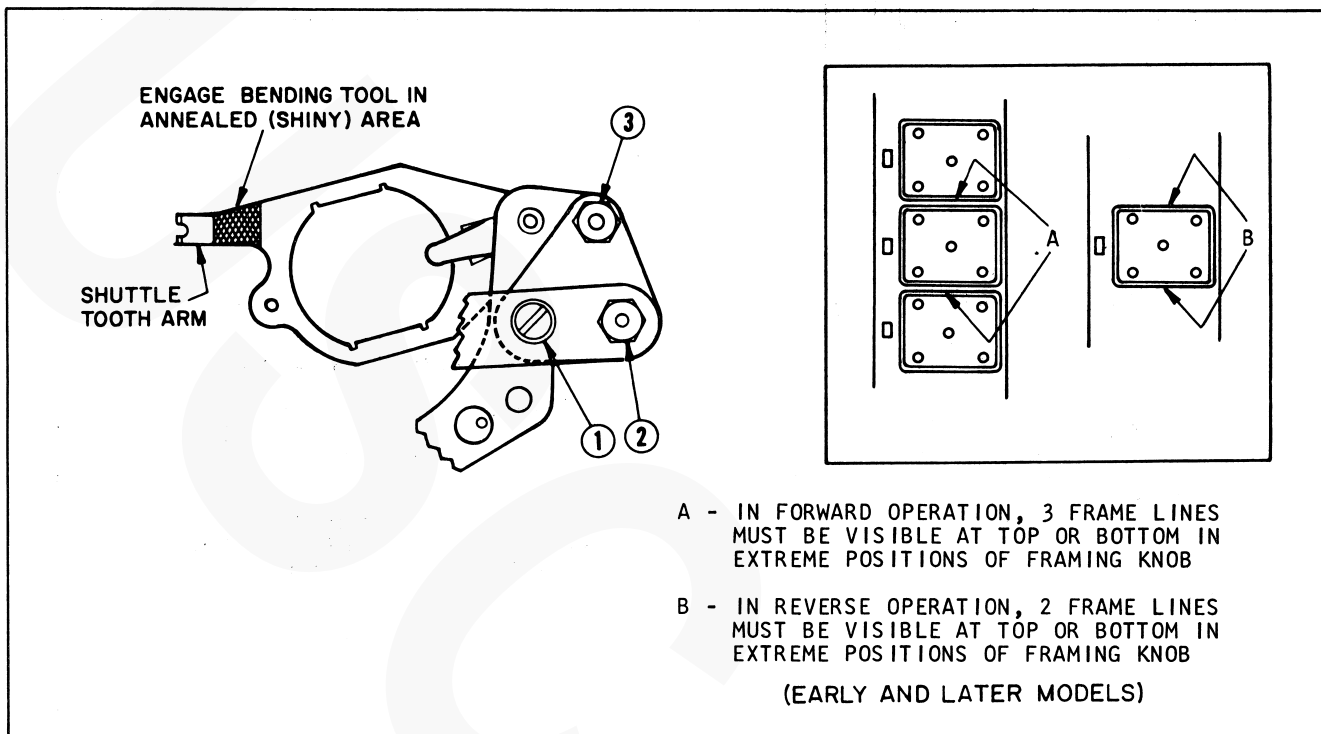

Figure F. Adjusting the Shuttle (Early Models Only)

moving bracket in either direction (See Figure H, item 7).

21. FRAMER ADJUSTMENT. The framing mechanism must be adjusted to permit maximum picture framing in either direction. Proceed in the following manner. Refer to Figure G.

a. Apply a light brushing of grease to the threads of framer shaft assembly. Assemble threaded end of framer knob and shaft assembly through the upper ear of mechanism plate. Position lens carrier assembly between the ears of the mechanism plate while pushing framer shaft through upper ear of carrier. Assemble collars (14, Figure 4), with threaded hole toward upper ear, and collar (15) onto framer shaft. Then push framer shaft through lower ear of lens carrier and thread into lower ear of mechanism plate. Thread shaft until end is just coming through the ear, and flat side is facing you.

b. Place a 0.027 shim between the lower ear of the mechanism casting and the lens carrier.

c. Hold the lens carrier against the shim. Hold the upper and lower collars (14, Figure 4) against the lens carrier ears and tighten the collar setscrews (11).

d. Place 0.100 spacer between the lower collar and the framer collar (15, Figure 4) and tighten the framer collar setscrew (11).

e. Framer knob must turn freely, without binding. If it does not, adjust the upper collar to free it.

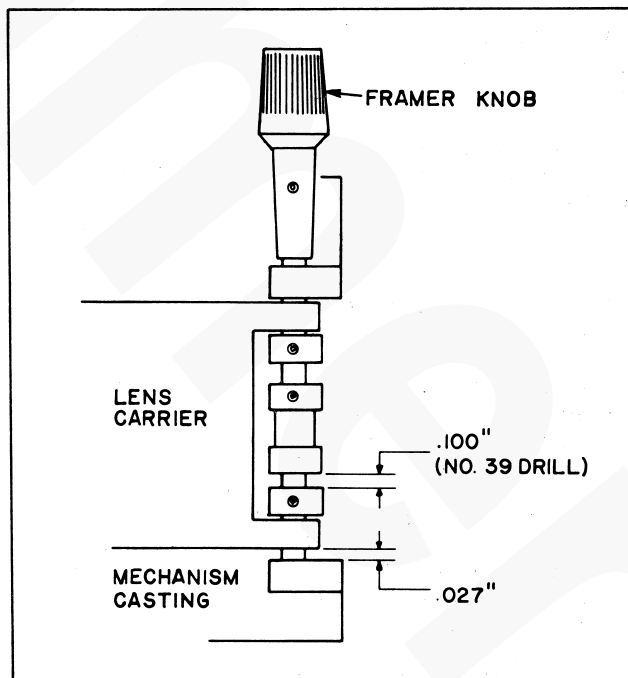

Figure G. Framer Adjustments

22. SAFETY SHUTTER ADJUSTMENT. The rubber drive rollers which drive the shutter pulley must make contact and begin driving the mechanism (in forward and in reverse) before the safety shutter clears the aperture opening. With the back cover removed and the projector line cord connected to the power source, switch on the projector. This test is to be made without film.

a. Operate the projector, first in the forward direction and then in the reverse direction. Watch the safety shutter carefully as the lever is moved from the "still" position to either of the operating positions.

b. Proper operation of the safety shutter is controlled by the clearance between the upper drive roller and the rim of the shutter (Figure H). The nominal clearance is 0.062 ± 0.015 inch. If, when operating in reverse, the safety shutter tends to clear the aperture opening before the shutter begins to revolve, this clearance should be increased toward the high (0.077) tolerance limit. If, when operating in forward, the safety shutter clears the aperture opening too soon, the clearance should be reduced toward the lower (0.047 inch) tolerance limit.

c. To adjust, place the lever in the "still" (center) position and loosen the two screws which attach the spring loading bracket to the pulley mounting bracket. Insert shim stock of the desired thickness (to increase or decrease nominal clearance of 0.062 inch) between upper drive roller and rim of shutter. While maintaining a light pressure on the roller, tighten the two loading bracket screws securely.

d. Retest safety shutter operation and readjust, if necessary, by changing the thickness of the shim stock inserted between roller and shutter rim.

23. APERTURE MASK ADJUSTMENT (Figure H).

a. With the back cover of the projector removed, adjust the aperture mask in the following manner: Place the projector switch in the "OFF" position and move the format shifting lever into the super 8-mm position. Place the projector switch into the "LAMP" position. Assemble shim (Figure B) between shifting lever and switch interlock. Adjust eccentric (1) by moving until the eccentric contacts the arm of the shifting lever. Tighten eccentric locking nut (2) to secure in position.

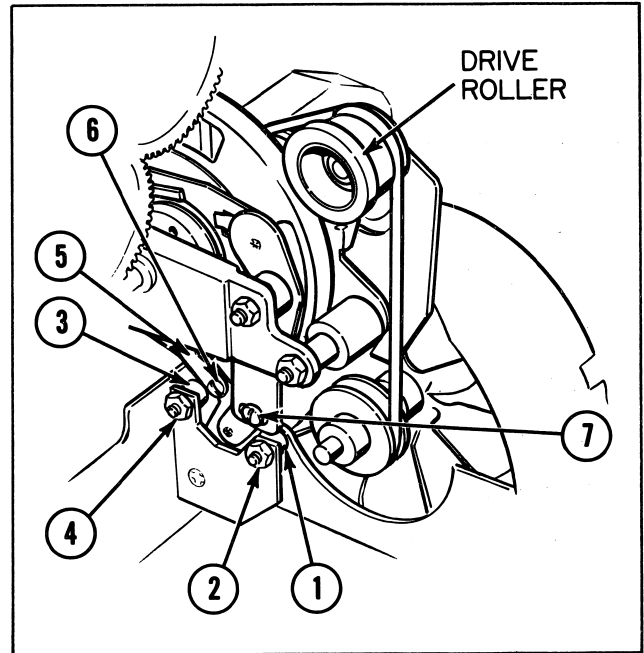

Figure H. Adjusting the Aperture Mask

b. Return projector switch to "OFF" position, and move the format shifting lever to the standard 8-mm position. Move projector switch back to the "LAMP" position. Assemble shim (Figure B) between shifting lever and switch interlock. Adjust eccentric (3) by moving it until it contacts the arm of the shifting lever. Tighten eccentric locking nut (4) to secure in position.

c. To check for aperture mask shifter centering, the lens carrier should be left open. Actuate the format shifting lever in both extremes of framer knob travel. Mask must completely shift from one format to the other, in either extreme of framing range. Also, mask actuating lever (5) must not touch actuating ears of mask after shifting to either format, and in both extremes of framing range. If the mask actuating lever (5) does not allow the mask to completely shift or is touching the ears of the mask, adjust the lever as necessary by loosening screw (6) and moving the lever in direction necessary.

SERVICE INSTRUCTIONS

LUBRICATION CHART

NOTE: When oil is specified, use Bell & Howell Spec. 1543.

ITEM	LUBRICATION
Interlock plate (2-19)	Grease (Spec. 1956) all surfaces contacting the control housing.
Gears (3-6, 3-7)	Grease (Spec. 1956) all gear teeth.
Bearings (3-21)	Grease (Spec. 1956) arms around bearings.
Reel arm supports (3-24)	Grease (Spec. 1956) all gear studs.
Gear mounting plate (3-25)	Grease (Spec. 1956) each gear stud.
Drive gear plate (4-17)	Grease (Spec. 1956) stud.
Lower loopformer (4-22)	Grease (Spec. 1956) roller shafts.
Upper loopformer (4-41)	Grease (Spec. 1956) roller shafts.
Snubber shaft (4-48)	Grease (Spec. 1956) actuating shaft.
Focus shaft (5-8)	Grease (Spec. 1956) end of shaft.
Pulley mounting bracket (6-16)	Grease (Spec. 1516) each stud.
Washer (6-25)	Grease (Spec. 1956) both sides.
Pull-down cam (6-31)	Grease (Spec. 1956) surfaces where shoes will make contact.

Final Test

24. GENERAL INSTRUCTIONS.

This section contains specific tests to be performed to insure that the projector is in proper working order. Tests will also serve to indicate the possible trouble or malfunction in the projector so that time can be saved in trouble shooting and servicing. Note that the projector is to be operated only from a 110 to 120 volts a-c, 60-cycle power source.

25. INSPECTION PROCEDURE.

a. Visually inspect the projector for missing parts. Pick up the projector, turn it over, and shake it to make sure that no loose parts are inside.

b. Check the blower cover screw for being securely tightened.

c. Check motor fan and blower fan for being securely tightened to the motor shaft by exerting hand pressure.

d. Check to see that the screws in the worm gear, and pull-up cam are securely tightened.

e. Check the end play of the drive roller shaft by pressing the end of the shaft. Drive roller must be under spring tension and springs must not be loose.

f. Check motor mounting screws for tightness.

g. Check all wires for being properly dressed out of the way, and check all solderless connectors for being securely pressed onto lugs.

h. Check four screws securing the loopformers for tightness. Check the operation of the loopformers and snubber lever for binding. Spring pressure must return the loopformers and snubber lever after actuating.

i. Open and close the lens carrier to make certain that it latches securely in place. If necessary, bend the fingers of the lens carrier catch to increase the tension.

j. Check the manual knob shaft for a slight amount of end play. Rotate manual knob to check the fit of the cam shoes. Cam shoes should fit snugly but without binding, and proper fit is obtained by selecting the appropriate combination of shoes.

26. SAFETY SHUTTER OPERATION TEST. It is important that the drive rollers, which drive the shutter pulley, make contact and begin driving the mechanism (either in forward or reverse) before the fire shutter clears the aperture opening. With the back cover removed and the projector connected to the power source, switch on the projector. This test is to be made without film. Operate the projector, first in the forward direction and then in reverse. Watch the action of the safety shutter and the drive rollers against the shutter rim as the lever is moved from the "still" position to either of the operating positions. If necessary, adjust drive rollers as instructed in paragraph 20.

27. OPERATIONAL TEST. Thread the projector with film, using a full reel, and run the projector to check for proper operation. Check the following items during the test.

a. Listen for unusual noises that may indicate insufficient lubrication.

b. If film should spill from the feed reel during operation, it is necessary to replace the reel spindle.

c. If the film fails to maintain its loop above or below the aperture, check the shuttle tooth height as described in paragraph 18, and readjust if necessary.

Replacement Parts

The following pages illustrate and list by part name and number all replacement parts of the Design 456A and 456Z Deluxe Autoload Standard and Super 8-mm Projector. The models A and Z are identical except for the projection lenses, as follows: 456A Standard lens part number 020749. 456Z, Zoom lens part number 020748. Since the illustrations are arranged in the suggested order of disassembly, they will serve as an aid to the repairman during disassembly and reassembly of the projector. Be sure to check footnotes for special instructions regarding replacement procedures.

NOTE

Refer to the Bristol Wrench Chart for proper wrenches required for removal of the fluted socket setscrews illustrated in these parts lists.

ACCESSORIES

- #012866 - 400 Ft. 8 mm Reel
- #40424 - Adapter, Spindle and Reel

FIG. & INDEX NO.	PART NO.	DESCRIPTION	UNITS PER ASSY	USABLE ON CODE
PROJECTOR COVERS AND LAMP				
1-1	09473	FRONT COVER ASSEMBLY	1	
-2	30226	. RIVET, Tubular, 0.123 inch diameter	1	
-3	39252	. CATCH, Cover.	1	
-4	32361	. BUTTON, Cover release	1	
-5	40553	. REEL CLIP	1	
-6	40488	. NAMEPLATE, Front cover	1	
-7	39274	. TRIMPLATE, Front cover	1	
-8	40556	. COVER, Front	1	
-9	29065	SCREW, Hex head tapping, No. 4-40 (type 23) by 1/2 inch	4	
-10	37932	SCREW, Hex head, 6-32 by 5/8 inch	2	
-11	40539	PLATE, Data	1	
-12	39181	CORD, Power	1	
-13	309761	BUSHING, Strain relief	1	
-14	39200	SCREW, Hex head tapping, 8-18 by 1/2 inch.	2	
-15	39124	HOOK, Power cord	2	
-16	39204	SCREW, Hex head sems tapping, 10-32 by 0.437 inch.	2	
-17	35186	WASHER, Flat	2	
-18	39129	END CAP, Handle	2	
-19	39074	HANDLE, Carrying	1	
-20	39073	INSERT, Handle.	1	
-21	40562	COVER, Back	1	
-22	09543	LAMPHOUSE ASSEMBLY	1	
-23	39190	. RIVET, Tubular, 0.123 inch diameter	1	
-24	39188	. BAFFLE, Heat	1	
-25	39189	. SPACER, Sleeve	1	
-26	35360	. CATCH, Lamphouse	1	
-27	NPN	. LAMPHOUSE (Order complete lamphouse assembly)	NP	
-28	40591	LAMP, Projection	1	
-29	40573	NAMEPLATE, Lamphouse	1	

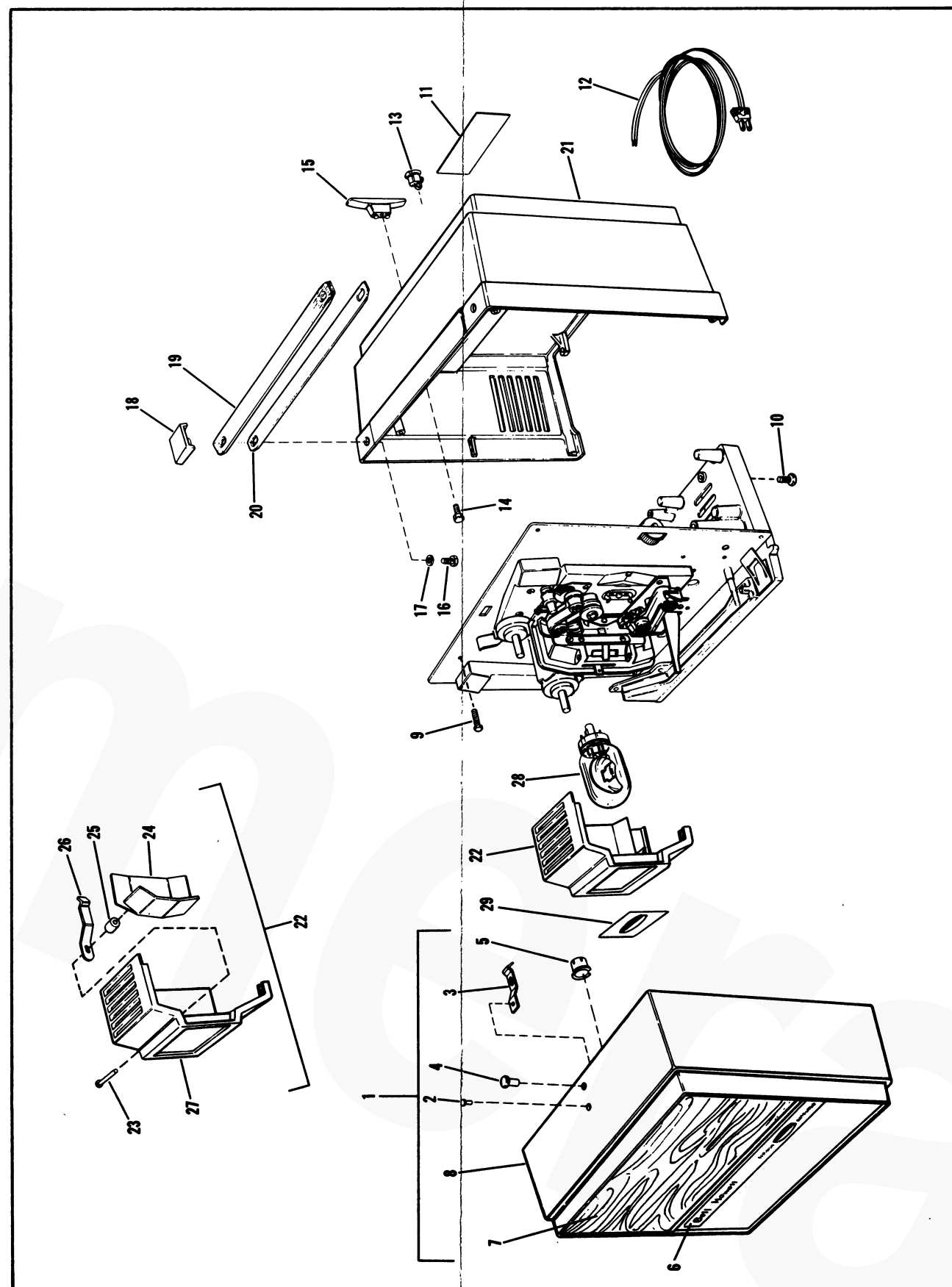

Figure 1. Projector Covers and Lamp

FIG. & INDEX NO.	PART NO.	DESCRIPTION	UNITS PER ASSY	USABLE ON CODE
CONTROL HOUSING AND ROLLERS				
2-1	19025	RIVET, Tubular, 0.123 inch diameter	2	
-2	32478	BAFFLE, Lamp	1	
-3	37947	SCREW AND WASHER, Sems, 4-40 by 1/4 inch	2	
-3A	30237	SCREW, Hex head tapping, No. 4-40 by 1/4 inch	1	
-4	39235	DEFLECTOR, Air	1	
-5	706679	SCREW, Hex head tapping, 6-32 by 3/8 inch	2	
-6	17632	WASHER, Flat	2	
-7	36882	SCREW, Hex head tapping, 6-32 by 3/8 inch	1	
-8	17632	WASHER, Flat	1	
-9	83286	CLAMP, Leadwire	1	
-10	010270	LAMP SOCKET AND BRACKET ASSEMBLY	1	
-11	39123	KNOB, Conversion	1	
-12	706679	SCREW, Hex head tapping, 6-32 by 3/8 inch	2	
-13	40409	HOUSING, Control	1	
-14	39182	TUBING, Vinyl	1	
-15	40487	NAMEPLATE, Control box, I	1	
-16	40486	NAMEPLATE, Control box, II	1	
-17	34590	SCREW, Flat head, 6-32 by 3/8 inch	2	
-18	40495	BUSHING, Interlock lever	2	
-19	40454	LEVER, Interlock	1	
-20	012860	SWITCH	1	
-21	36882	SCREW, Hex head tapping, 6-32 by 3/8 inch	1	
-22	19327	NUT	1	
-23	20808	RING, Retaining, 0.145 inch ID (IRRC 1000-18)	2	
-24	39087	ROLLER, Guide	1	
-25	40419	GUIDE, Film	1	
-26	39173	SPACER, Sleeve	1	
-27	39098	SPRING, Torsion	1	
-28	39137	SHAFT, Roller	1	
-29	39089	SCREW, Guide roller, special, 4-40 NC	2	
-30	39223	NUT, Plain hex, 4-40 NC	1	
-31	39248	ROLLER, Guide	1	
-32	40518	ROLLER	1	
-33	39143	DEFLECTOR, Film	1	
-34	36714	KNOB, Tilt	1	
-35	39125	STUD, Tilt knob	1	
-36	32926	SCREW, Fillister head, 2-56 by 1/4 inch	1	
-37	40420	KNOB, Forward - reverse	1	
-38	39225	NAMEPLATE, DJL Lamp	1	

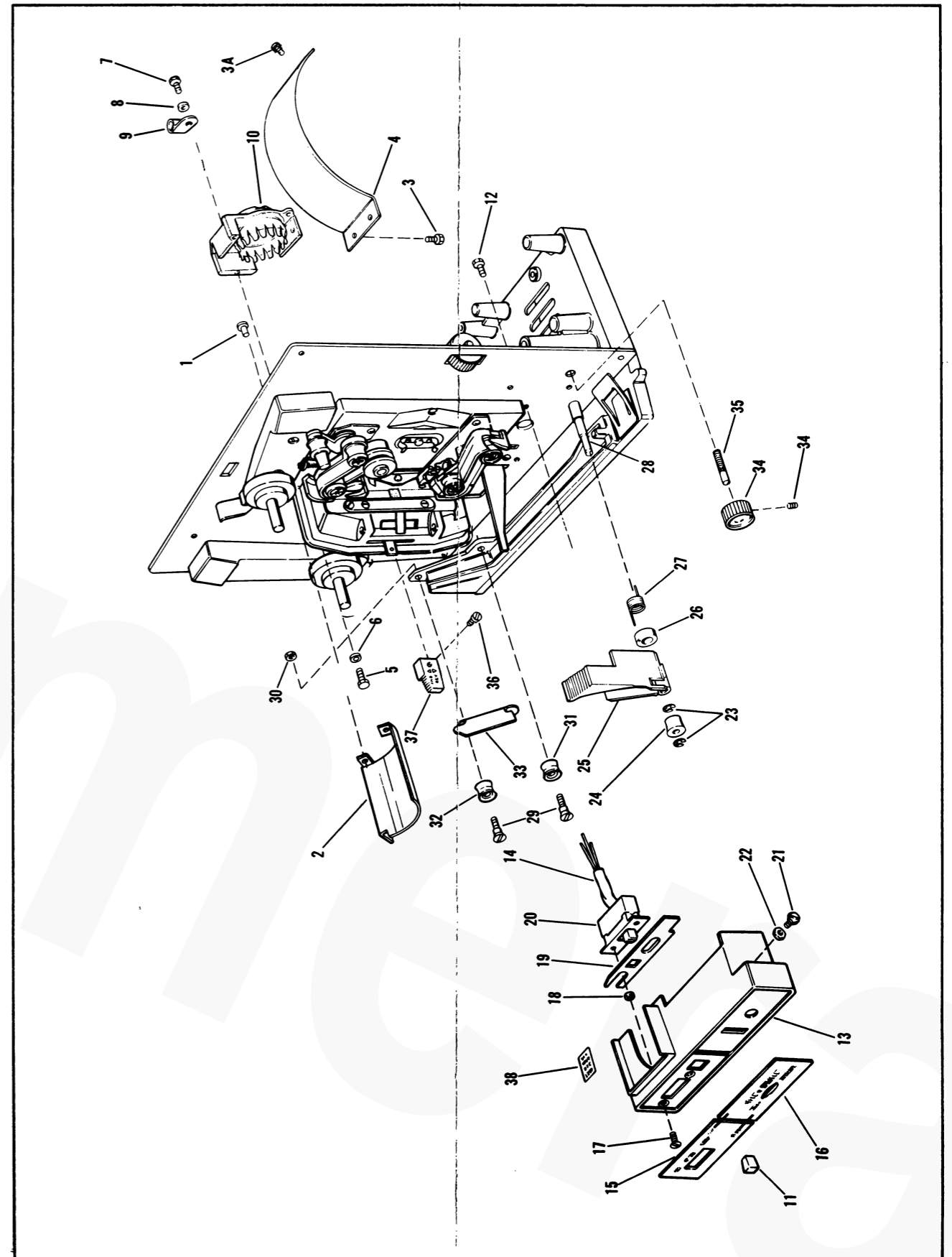

Figure 2. Control Housing and Rollers

FIG. & INDEX NO.	PART NO.	DESCRIPTION	UNITS PER ASSY	USABLE ON CODE
REEL ARMS AND GEAR				
3-1	23822	SCREW, Binding head, 5-40 by 0.203 inch	4	
-2	36837	SCREW, Pan head, 4-40 by 1/4 inch	2	
-3	40405	ARM, Reel	2	
-4	40415	GEAR, Spur	2	
-5	09578	REEL SPINDLE ASSEMBLY	1	
-6	29707	GEAR, Spur	4	
-7	39049	GEAR, Spur	2	
-8	34874	WASHER	4	
-9	29192	SETSCREW, Fluted socket cup pt, 4-40 by 1/8 inch	1	
-10	35176	GEAR, Spur	1	
-11	010189	SPUR GEAR AND SHAFT ASSEMBLY	1	
-12	29192	SETSCREW, Fluted socket cup pt, 4-40 by 1/8 inch	1	
-13	39056	GEAR, Spur	1	
-14	010189	SPUR GEAR AND SHAFT ASSEMBLY	1	
-15	21736	RING, Retaining, 0.207 inch ID (IRRC 1000-25)	4	
-16	29706	GEAR, Spur, small	2	
-17	34718	GEAR, Spur, large	2	
-18	31015	WASHER, Spring tension	1	
-19	80147	SCREW, Phillips binding head, 5-40 by 3/16 inch	1	
-20	29744	RING, Retaining, external, 0.562 inch ID	2	
-21	34705	BEARING, Reel arm	2	
-22	09559	SUPPORT AND REWIND LEVER ASSEMBLY	1	
-23	012863	STUD AND SUPPORT ASSEMBLY	1	
-24	010273	GEAR MOUNTING PLATE ASSEMBLY	1	
-25	39099	SPRING, Reel arm tension	2	
-26	29736	WASHER, Cam, feed arm	1	
-27	39228	WASHER, Cam, take-up arm	1	
-28	1261	BALL, Steel	2	

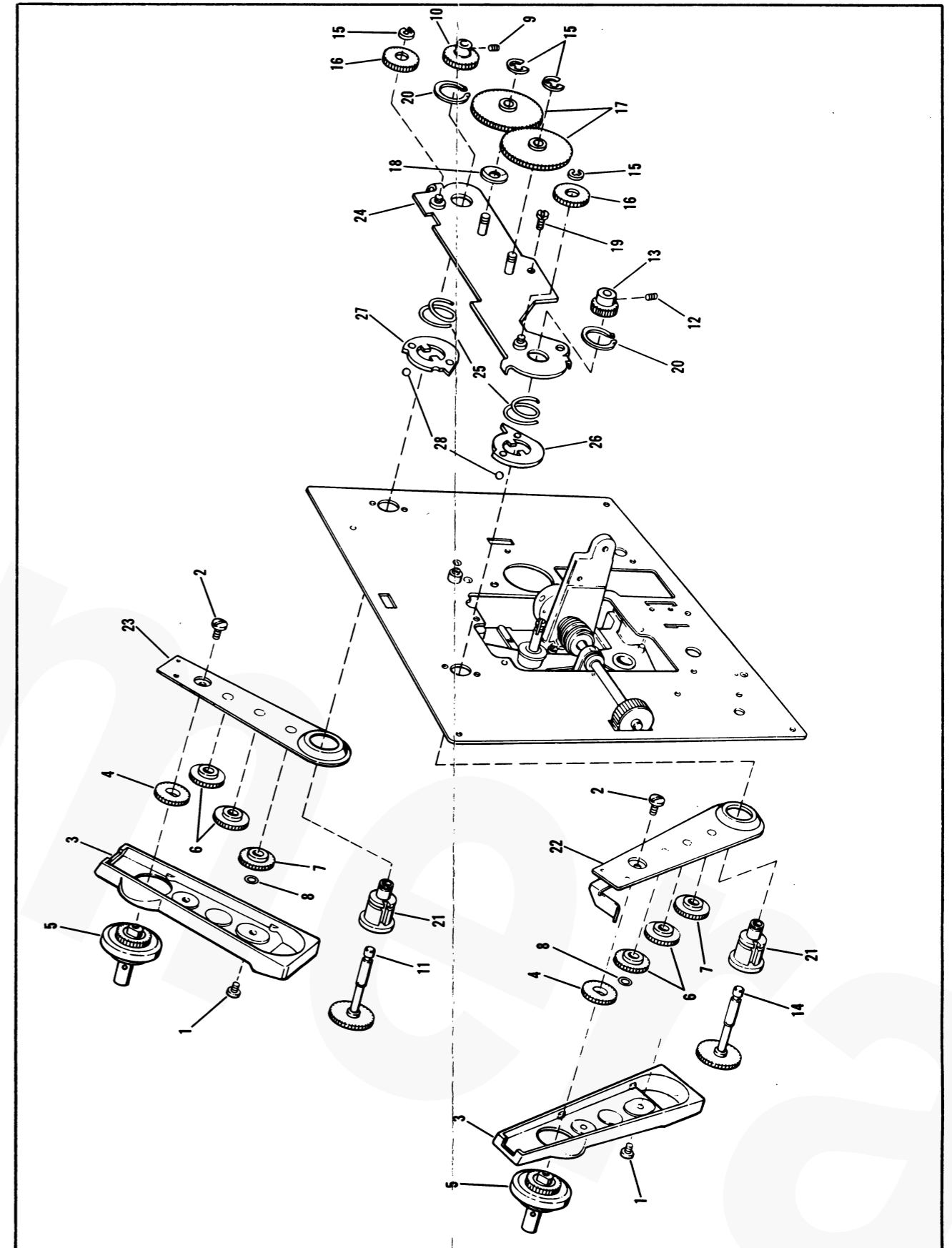

Figure 3. Reel Arms and Gear

(FIG. 3)

SERVICE INSTRUCTIONS

FIG. & INDEX NO.	PART NO.	DESCRIPTION							UNITS PER ASSY	USABLE ON CODE
		1	2	3	4	5	6	7		
LOOPFORMERS, SPROCKETS AND GEARS										
4-1	21736	RING, Retaining, 0.207 inch ID (IRRC 1000-25)							1	
-2	34718	GEAR, Spur							1	
-3	35181	SPRING, Gear retaining							1	
-4	35184	RATCHET, Spring							1	
-5	35186	WASHER, Spacer							1	
-6	35177	GEAR ASSEMBLY, Outer							1	
-7	011459	DRIVE GEAR LEVER AND STUD ASSEMBLY							1	
-8	39005	GEAR, Inner							1	
-9	09624	FILM DRIVE ROLLER AND SHAFT ASSEMBLY							1	
-10	26085	WASHER, Friction							2	
-11	29192	SETSCREW, Fluted socket cup pt, 4-40 by 1/8 inch							4	
-12	09618	FRAMER KNOB ASSEMBLY							1	
-13	40476	PIN, Pivot, lens mount							1	
-14	40479	COLLAR							2	
-15	40462	COLLAR, Frammer							1	
-16	36836	SCREW, Pan head, 4-40 by 3/16 inch							6	
-17	40412	GUIDE, Film, lower							1	
-18	09627	LOWER LOOPFORMER ASSEMBLY							1	
-19	40567	. RING, Self-locking, retaining, external							2	
-20	40492	. WASHER							2	
-21	40536	. ROLLER							2	
-22	40413	. LOOPFORMER, Lower							1	
-23	29192	SETSCREW, Fluted socket cup pt, 4-40 by 1/8 inch							4	
-24	40468	BUSHING							2	
-25	705972	WASHER, Thrust							2	
-26	09629	LOWER LOOPFORMER MOUNTING PLATE ASSEMBLY							1	
-27	17639	. RING, Retaining							2	
-28	17188	. WASHER, Spring							1	
-29	40473	. SHAFT, Spring, lower							1	
-30	40541	. SPRING, Snubber							1	
-31	40446	. PLATE, Spring stop, lower							1	
-32	40559	. BUMPER, Lower snubber							1	
-33	NPN	. PLATE, Lower (Order complete lower loopformer mtg plate . . assembly)							1	
-34	36838	SCREW, Pan head, 4-40 by 3/8 inch							1	
-35	40410	GUIDE, Film, upper							1	
-36	09626	UPPER LOOPFORMER ASSEMBLY							1	
-37	40567	. RING, Self-locking, retaining, external							2	
-38	40492	. WASHER							2	
-39	40536	. ROLLER							1	
-40	40535	. ROLLER, Guide							1	
-41	40411	. LOOPFORMER, Upper							1	
-42	09622	THREADING KNOB ASSEMBLY							1	
-43	20808	RING, Retaining, 0.145 inch ID (IRRC 1000-18)							1	
-44	40585	ROLLER							1	
-45	34878	SHIM							1	
-46	40561	SPRING							1	
-47	20808	RING, Retaining							1	
-48	09619	SNUBBING ARM AND PIVOT SHAFT ASSEMBLY							1	
-49	40530	SPRING, Upper snubber							1	
-50	09628	UPPER LOOPFORMER MOUNTING PLATE ASSEMBLY							1	
-51	17639	. RING, Retaining							2	
-52	17188	. WASHER, Spring							1	
-53	40577	. SHAFT, Spring, upper							1	
-54	40543	. SPRING, Top, snubber							2	
-55	09616	. UPPER SPRING STOP PLATE AND SLEEVE ASSEMBLY							2	
-56	40541	. SPRING, Snubber							1	
-57	NPN	. PLATE, Upper (Order complete upper loopformer mtg plate . . assembly)							1	
-58	40467	RIVET, Lens mount catch							2	
-59	40533	SCREW, Hex head, 4-40 by 1/4 inch							1	

FIG. & INDEX NO.	PART NO.	DESCRIPTION	UNITS PER ASSY	USABLE ON CODE
LOOPFORMERS, SPROCKETS AND GEARS				
4-60	09630	LENS MOUNT CATCH ASSEMBLY	1	
-61	40621	SHIM	2	
-62	30621	SCREW, Truss head, 3-48 by 3/16 inch	1	
-63	40551	SCREW, Truss head, 3-48 by 1/4 inch	1	
-64	30620	SCREW, Truss head, 3-48 by 1/8 inch	2	
-65	40531	SPRING, Side tension	1	
-66	30639	ARM, Side tension	1	
-67	40440	GUIDE, Film	1	
-68	40494	SPRING, Fire shutter	1	
-69	*08212	APERTURE PLATE ASSEMBLY	1	
-69	*07887	APERTURE PLATE ASSEMBLY	1	
-70	40444	SHIM, Upper aperture plate (Early Models Only)	1	
-71	40445	SHIM, Bottom aperture plate (Early Models Only)	1	
-72	39214	NAMEPLATE, Rewind position	1	
-73	09694	LENS CARRIER ASSEMBLY (See Figure 5)	1	
-74	25108	WASHER, Shim	1	

*Projectors below Serial No. BT57901 used aperture plate assembly 08212. Those above BT57901 used aperture plate assembly 07887.

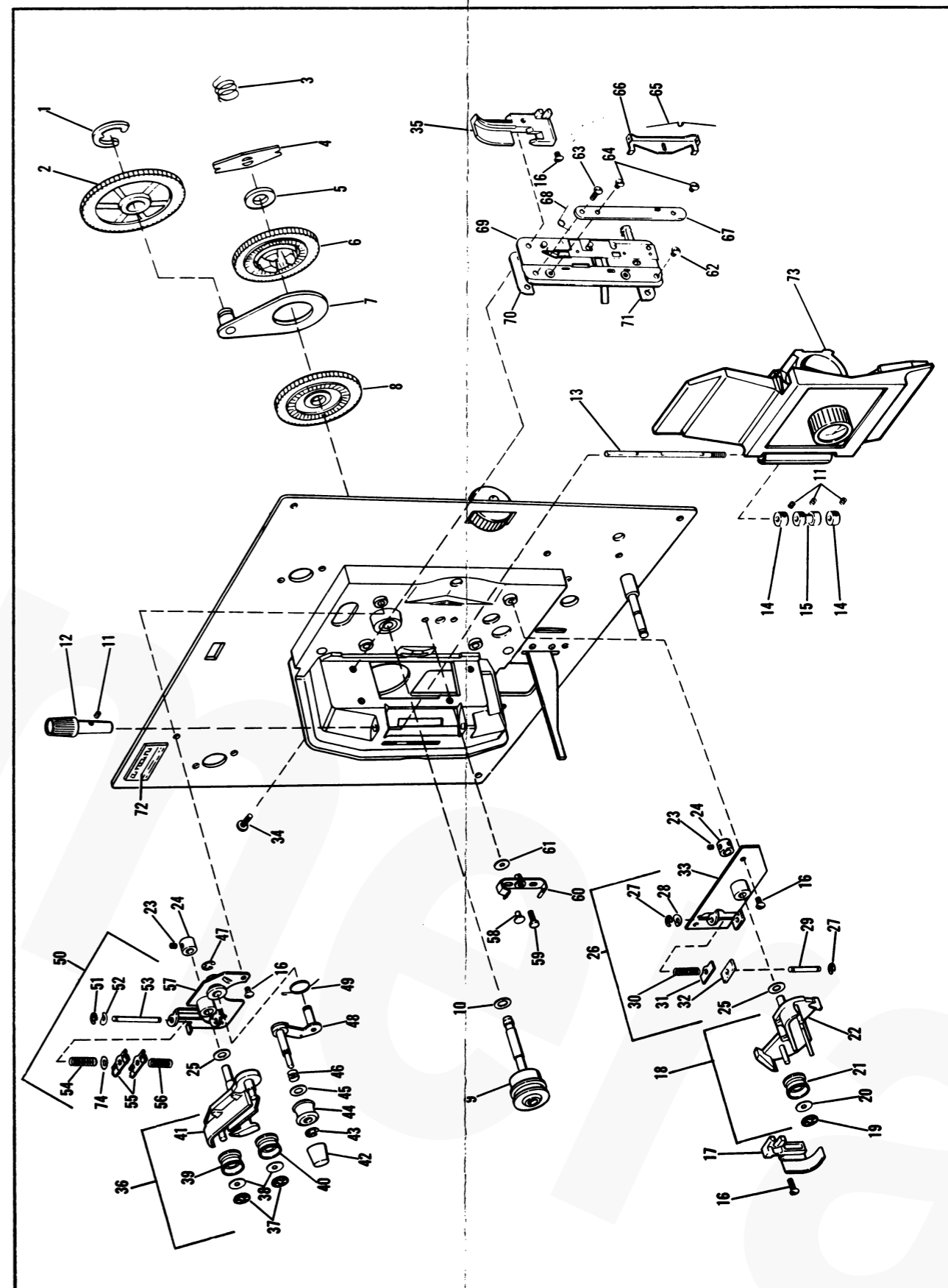

Figure 4. Loopformers, Sprockets and Gears

SERVICE INSTRUCTIONS

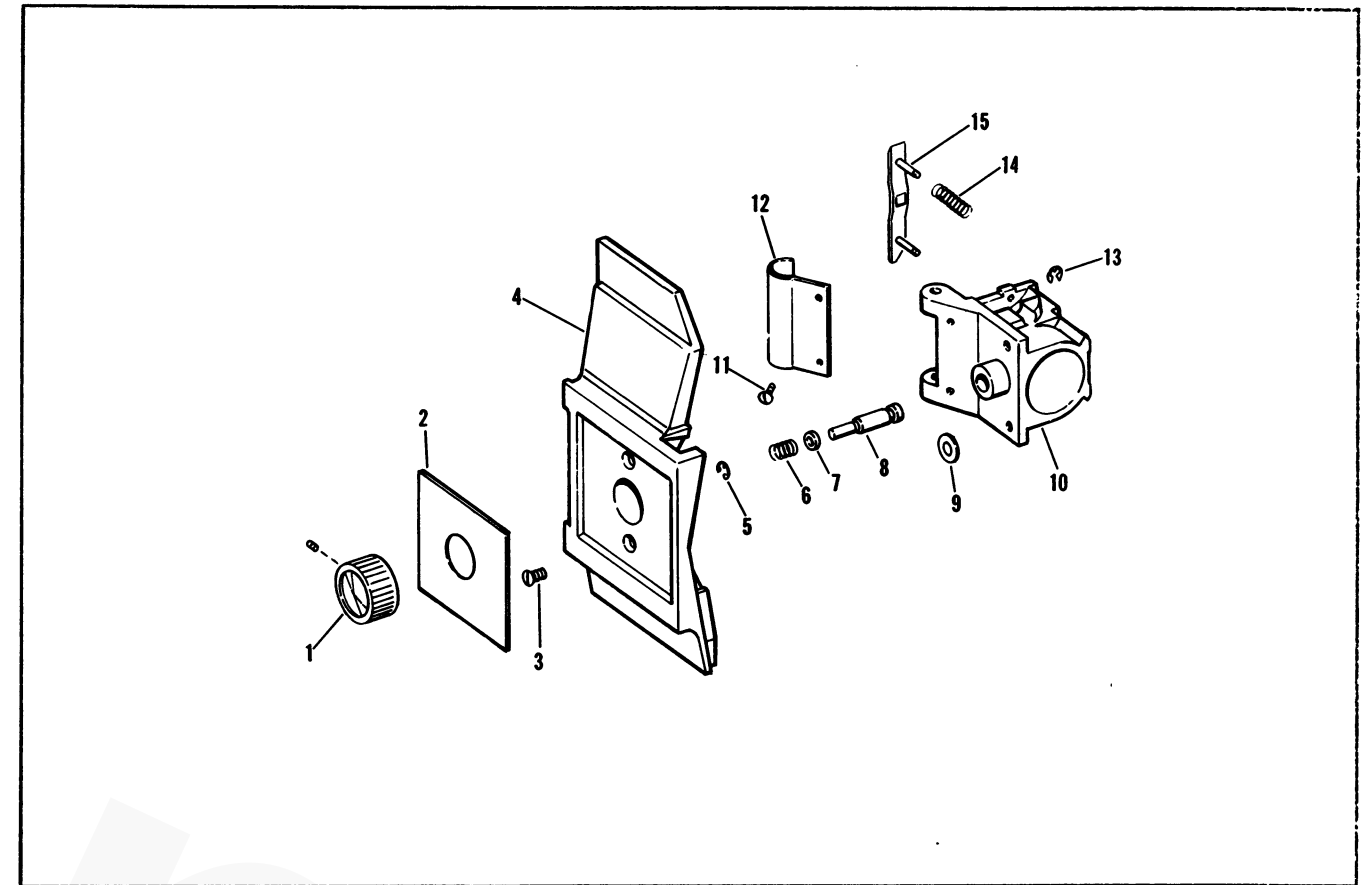

Figure 5. Lens Carrier Assembly

FIG. & INDEX NO.	PART NO.	DESCRIPTION	UNITS PER ASSY	USABLE ON CODE
LENS CARRIER ASSEMBLY				
5-	09694	LENS CARRIER ASSEMBLY	1	
-1	36714	. KNOB, Focus	1	
-2	40489	. PLATE, Trim	1	
-3	25618	. SCREW, Pan head, 6-32 by 9/16 inch	2	
-4	40586	. COVER, Lens carrier	1	
-5	20808	. RING, Retaining	1	
-6	39097	. SPRING, Focus	1	
-7	39230	. WASHER	1	
-8	09621	. FOCUS SHAFT AND PIN ASSEMBLY	1	
-9	17632	. WASHER, Flat	2	
-10	09617	. LENS MOUNT AND BUSHING ASSEMBLY	1	
-11	36836	SCREW, Pan head, 4-40 by 3/16 inch	2	
-12	40485	PLATE, Cover	1	
-13	40564	RING, E, external, retaining	2	
-14	40542	SPRING, Pressure plate	2	
-15	012867	PRESSURE PLATE AND STUD ASSEMBLY	1	

FIG. & INDEX NO.	PART NO.	DESCRIPTION	UNITS PER ASSY	USABLE
				ON CODE
PROJECTOR BASE AND MOTOR				
7-1	29065	SCREW, Hex head tapping, 4-40 by 1/2 inch (type 23)	3	
-2	09882	MECHANISM PLATE AND MAIN PLATE ASSEMBLY	1	
-3	21736	RING, Retaining, 0.207 inch ID (IRRC No. 1000-25)	1	
-4	010373	TILT SHAFT ASSEMBLY	1	
-5	37885	BELT, Drive	1	
-6	12498	SETSCREW, Fluted socket cup pt, 6-32 by 1/8 inch.	1	
-7	36564	PULLEY, Drive	1	
-8	32974	SETSCREW, Fluted socket cup pt, 8-32 by 1/8 inch	1	
-9	012608	FAN BLADE AND HUB ASSEMBLY	1	
-10	32485	FAN, 2-Bladed	1	
-11	700454	SCREW, Pan head sems, 6-32 by 3/8 inch	3	
-12	39065	INSERT, Mounting	3	
-13	28718	WASHER, Flat	1	
-14	39177	GROMMET, Motor mounting	3	
-15	26906	NUT AND WASHER, Sems, 6-32NC	2	
-16	17632	WASHER, Flat	2	
-17	32774	SCREW, Round head, No. 6-32 by 5/8 inch	2	
-18	39048	BRACKET, Motor mounting, long	1	
-19	39058	BRACKET, Motor mounting, short	1	
-20	012607	MOTOR ASSEMBLY	1	
-21	36882	SCREW, Hex head tapping 6-32 by 3/8 inch	1	
-22	17632	WASHER, Flat	1	
-23	39185	CLAMP, Leadwire	1	
-24	09625	BASE ASSEMBLY	1	
-25	32652	· RIVET, Tubular, 0.123 inch diameter	3	
-26	26135	· FOOT, Rubber	2	
-27	40572	· RIVET	2	
-28	40498	· GUIDE, Film cutter	1	
-29	40497	· CUTTER, Film	1	
-30	40501	· SPACER, Film cutter	1	
-31	NPN	· BASE (Order complete base assembly)	NP	

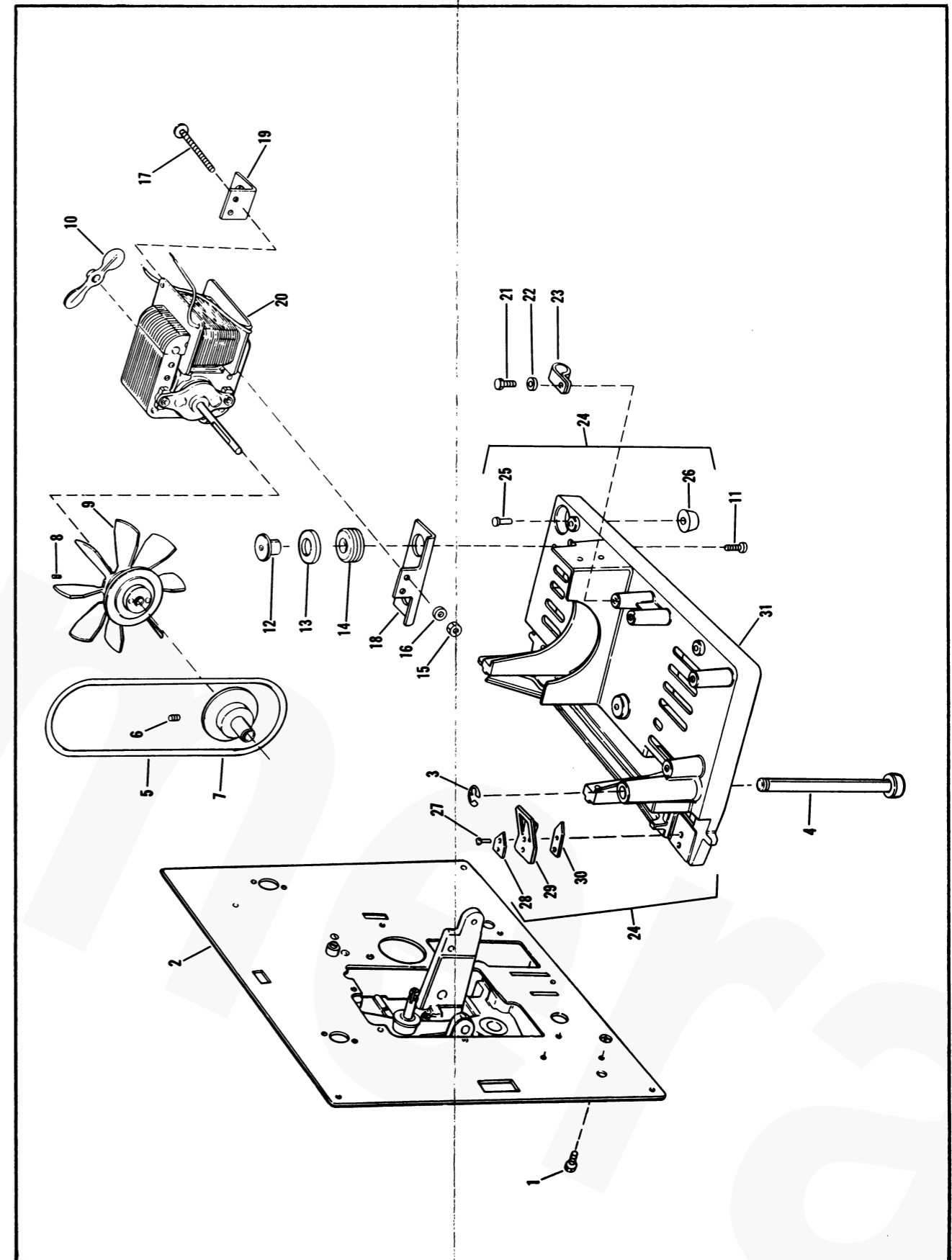

Figure 7. Projector Base and Motor

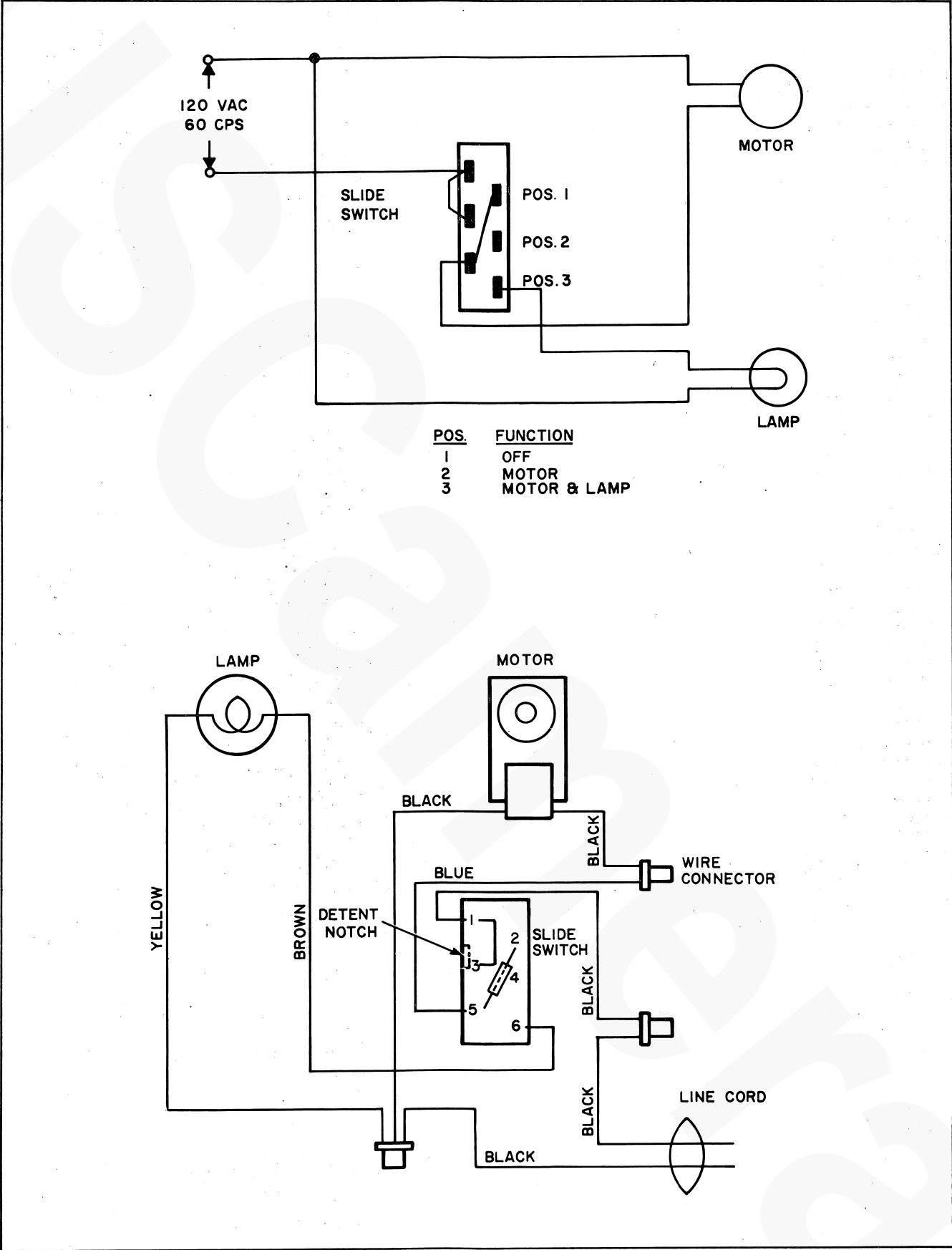

Figure 8. Schematic and Wiring Diagrams

(FIG. 8)

SERVICE INSTRUCTIONS

NUMERICAL INDEX OF PARTS

PART NO.	FIG. & INDEX NO.	PART NO.	FIG. & INDEX NO.	PART NO.	FIG. & INDEX NO.	PART NO.	FIG. & INDEX NO.
010189	3-11, 3-14	28718	7-13	39030	6-31	40467	4-58
010270	2-10	29065	1-9, 7-1	39048	7-18	40468	4-24
010273	3-24	29175	6-20	39049	3-7	40473	4-29
010348	6-10	29192	3-9, 3-12,	39056	3-13	40474	6-3
010373	7-4		4-11, 4-23	39058	7-19	40476	4-13
010667	6-15	20706	3-16	39065	7-12	40479	4-14
011459	4-7	29707	3-6	39073	1-20	40485	5-12
012593	6-16	29736	3-26	39074	1-19	40486	2-16
012607	7-20	29744	3-20	39087	2-24	40487	2-15
012608	7-9	30226	1-2	39089	2-29	40488	1-6
012860	2-20	30237	2-3A	39097	5-6	40489	5-2
012863	3-23	30551	6-19	39098	2-27	40492	4-20, 4-38
012867	5-15	30620	4-64	39099	3-25	40494	4-68
07887	4-69	30621	4-62	39123	2-11	40495	2-18
08212	4-69	30639	4-66	39124	1-15	40497	7-29
09167	6-18	30667	6-39	39125	2-35	40498	7-28
09473	1-1	309761	1-13	39129	1-18	40501	7-30
09543	1-22	31015	3-18	39137	2-28	40518	2-32
09559	3-22	32172	6-14	39140	6-36	40530	4-49
09578	3-5	32350	6-1	39143	2-33	40531	4-65
09616	4-55	32361	1-4	39173	2-26	40533	4-59
09617	5-10	32478	2-2	39177	7-14	40535	4-40
09618	4-12	32485	7-10	39181	1-12	40536	4-21, 4-39
09619	4-48	32652	7-25	39182	2-14	40539	1-11
09620	6-5	32774	7-17	39185	7-23	40541	4-30, 4-56
09621	5-8	32926	2-36	39188	1-24	40542	5-14
09622	4-42	32947	6-29	39189	1-25	40543	4-54
09623	6-6	32974	7-8	39190	1-23	40551	4-63
09624	4-9	33039	6-38	39200	1-14	40553	1-5
09625	7-24	33712	6-29	39204	1-16	40556	1-8
09626	4-36	33968	6-4	39214	4-72	40559	4-32
09627	4-18	34590	2-17	39223	2-30	40561	4-46
09628	4-50	34656	6-9	39225	2-38	40562	1-21
09629	4-26	34705	3-21	39228	3-27	40564	5-13
09630	4-60	34718	3-17, 4-2	39230	5-7	40567	4-19, 4-37
09690	6-26	34874	3-8	39235	2-4	40570	6-27
09694	5-, 4-73	34878	4-45	39245	6-12	40572	7-27
09882	7-2	35176	3-10	39248	2-31	40573	1-29
12498	6-33, 7-6	35177	4-6	39252	1-3	40577	4-53
1261	3-28	35181	4-3	39263	6-42	40581	6-7
17188	4-28, 4-52	35184	4-4	39264	6-8	40582	6-28
17632	2-6, 2-8, 5-9,	35186	1-17, 4-5	39274	1-7	40583	6-23
	7-16, 7-22	35360	1-26	40405	3-3	40585	4-44
17639	4-27, 4-51	35956	6-17	40409	2-13	40586	5-4
19025	2-1	36564	7-7	40410	4-35	40591	1-28
19327	2-22	36714	2-34, 5-1	40411	4-41	40621	4-61
20808	2-23, 4-43,	36765	6-30	40412	4-17	700454	7-11
	4-47, 5-5	36836	4-16, 5-11	40413	4-22	705972	4-25
21736	3-15, 4-1,	36837	3-2	40415	3-4	706679	2-5, 2-12
	7-3	36838	4-34	40419	2-25	80147	3-19
23822	3-1	36882	2-7, 2-21,	40420	2-37	80591	6-35
25108	4-74		7-21	40430	6-22	83286	2-9
25618	5-3	27885	7-5	40431	6-21		
25715	6-11	37932	1-10	40432	6-40		
26085	4-10, 6-32	37947	2-3	40440	4-67		
26131	6-37	39004	6-34	40444	4-70		
26135	7-26	39005	4-8	40445	4-71		
26906	6-2, 6-24,	39010	6-41	40446	4-31		
	7-15	39011	6-43	40454	2-19		
27322	6-13	39027	6-25	40462	4-15		